

LAMPIRAN

HASIL KALIBRASI

A. Data Pelanggan

1. Nama Pelanggan : Teknik Elektromedik UMY
2. Nama Alat : Autoclave
3. Merek : Getinge
4. Tipe : 533HC
5. No. Seri : URA011127 / AM-0837

B. Pelaksanaan Kalibrasi

1. Tempat/Ruangan : Laboratorium
2. Tanggal : 5 September 2017
3. Petugas : Khresna Bayu

C. Kondisi Lingkungan

1. Suhu : 26,5 °C
2. Kelembaban : 72 % RH

D. Pengukuran Kinerja

1. Data 1

Rata-rata Modul (°C)	Rata-rata autoclave (°C)	Simpangan	Error (%)	Koreksi (°C)	Ketidakpastian
55,716	58	2,284	4%	2,284	6.771646

2. Waktu

Pembacaan Standar	
Menit	Detik
90	0

METODE ANALISIS DATA

1. PERHITUNGAN DATA I

a. Rata – rata

$$\text{Rata – Rata } (\bar{X}) = \frac{\sum X_i}{n}$$

Dimana : \bar{X} = rata-rata

$\sum X_i$ = Jumlah nilai data

n = Banyak data (1,2,3,...,n)

1) Rata – rata pengukuran suhu

a) Rata-rata suhu pada modul TA

$$\begin{aligned} \text{Rata – Rata } (\bar{X}) &= \frac{\sum X_i}{n} \\ &= (25.25+37.94+50.64+63.33+76.03+88.72+101.42+88.72+76.0 \\ &3+63.33+50.64+37.94+25.25+25.25+25.25)/15 \\ &= 55.716 \end{aligned}$$

b) Rata-rata suhu pada alat pembanding (Autoclave)

$$\begin{aligned} \text{Rata – Rata } (\bar{X}) &= \frac{\sum X_i}{n} \\ &= (25+40+55+65+75+90+105+90+80+65+50+40+25+25+25) \\ &/15 \\ &= 57 \end{aligned}$$

b. Simpangan

\bar{X}

$$\text{Simpangan} = Y -$$

Dimana : Y = data setting

\bar{X} = rata-rata hasil pengukuran

$$\text{Simpangan} = Y - \bar{X}$$

$$= 57 - 55,716$$

$$= 1,284$$

c. Error %

$$\text{Error} = \left(\frac{\text{data setting} - \text{rata-rata}}{\text{data setting}} \right) \times 100\%$$

$$\text{Error} = \left(\frac{57 - 55,716}{57} \right) \times 100\%$$

$$= 2\%$$

2. PERHITUNGAN DATA II

a. Rata-rata

$$\text{Rata-rata} (\bar{X}) = \frac{\sum Xi}{n}$$

Dimana : \bar{X} = rata-rata

$\sum Xi$ = Jumlah nilai data

n = Banyak data (1,2,3,...,n)

1) Rata-rata pengukuran suhu

a) Rata-rata suhu pada modul TA

$$\begin{aligned} \text{Rata - Rata } (\bar{X}) &= \frac{\sum xi}{n} \\ &= (50.64+63.33+76.03+88.72+101.42+101.42+101.42+114.11+ \\ &114.11+114.11+101.42+101.42+76.03+50.64+37.94)/15 \\ &= 86.184 \end{aligned}$$

b) Rata-rata suhu pada alat pembanding (Autoclave)

$$\begin{aligned} \text{Rata - Rata } (\bar{X}) &= \frac{\sum xi}{n} \\ &= (55+65+75+90+105+105+114+114+114+114+100+100+80+ \\ &60+40)/15 \\ &= 88.73333333 \end{aligned}$$

b. Simpangan

$$\text{Simpangan} = Y - \bar{X}$$

Dimana : Y = data setting

\bar{X} = rata-rata hasil pengukuran

$$\text{Simpangan} = Y - \bar{X}$$

$$= 88.73333333 - 86.184$$

$$= 2.549333333$$

c. Error %

$$\text{Error} = \left(\frac{\text{data setting} - \text{rata}}{\text{data setting}} \right) \times 100\%$$

$$\text{Error} = \left(\frac{88.73333333 - 86.184}{88.73333333} \right) \times 100\%$$

$$= 3\%$$

3. PERHITUNGAN DATA III

a. Rata – rata

$$\text{Rata – Rata } (\bar{X}) = \frac{\sum Xi}{n}$$

Dimana : \bar{X} = rata-rata

$\sum Xi$ = Jumlah nilai data

n = Banyak data (1,2,3,...,n)

1) Rata – rata pengukuran suhu

a) Rata-rata suhu pada modul TA

$$\text{Rata – Rata } (\bar{X}) = \frac{\sum Xi}{n}$$

$$\begin{aligned} &= (37.94+50.64+63.33+63.33+63.64+63.64+63.33+76.03+76.03 \\ &+76.03+88.72+101.42+101.42+101.42+88.72)/15 \\ &= 74.376 \end{aligned}$$

b) Rata-rata suhu pada alat pembanding (Autoclave)

$$\text{Rata – Rata } (\bar{X}) = \frac{\sum Xi}{n}$$

$$\begin{aligned} &= (40+55+65+65+65+65+65+75+75+75+90+110+110+114+90) \\ &/15 \\ &= 77.26666667 \end{aligned}$$

b. Simpangan suhu

$$\text{Simpangan} = Y - \bar{X}$$

Dimana : Y = data setting

\bar{X} = rata-rata hasil pengukuran

$$\begin{aligned}\text{Simpangan} &= Y - \bar{X} \\ &= 77.26666667 - 74.376 \\ &= 2.890666667\end{aligned}$$

c. Error %

$$\text{Error} = \left(\frac{\text{data setting} - \text{rata-rata}}{\text{data setting}} \right) \times 100\%$$

$$\text{Error} = \left(\frac{77.26666667 - 74.376}{77.26666667} \right) \times 100\%$$

$$= 4\%$$

SKEMATIK RANGKAIAN ARDUINO

Arduino™ UNO Reference Design

Reference Designs ARE PROVIDED "AS IS" AND "WITH ALL FAULTS". Atmel DISCLAIMS ALL OTHER WARRANTIES, EXPRESS OR IMPLIED, REGARDING PRODUCTS, INCLUDING BUT NOT LIMITED TO, ANY IMPLIED WARRANTIES OF MERCHANTABILITY OR FITNESS FOR A PARTICULAR PURPOSE. Atmel may make changes to specifications and product descriptions at any time, without notice. The Customer must not rely on the absence or characteristics of any features or instructions marked "reserved" or "undefined". Atmel reserves the right to discontinue or alter specifications without notice. The product information on the Web Site or Materials is subject to change without notice. Do not finalize a design with this information.

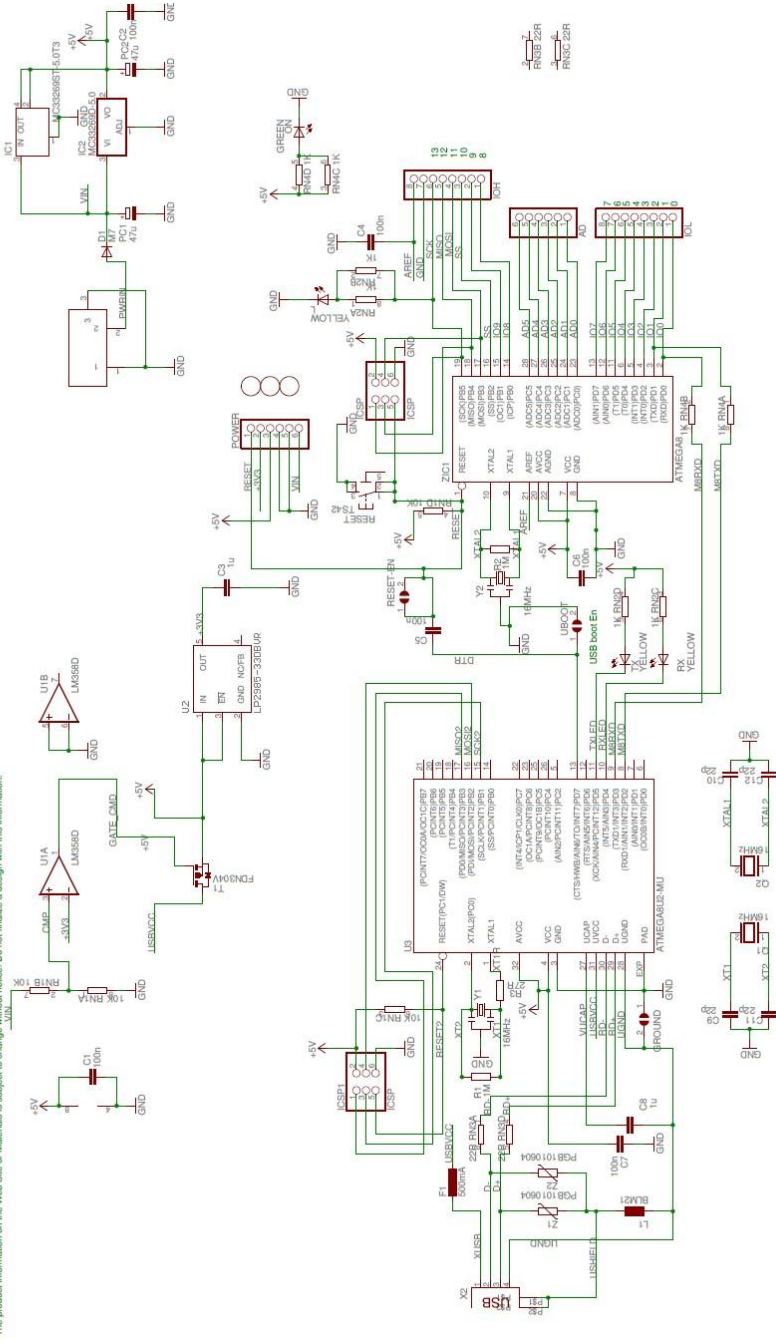

SKEMATIK RANGKAIAN MODUL CHARGER

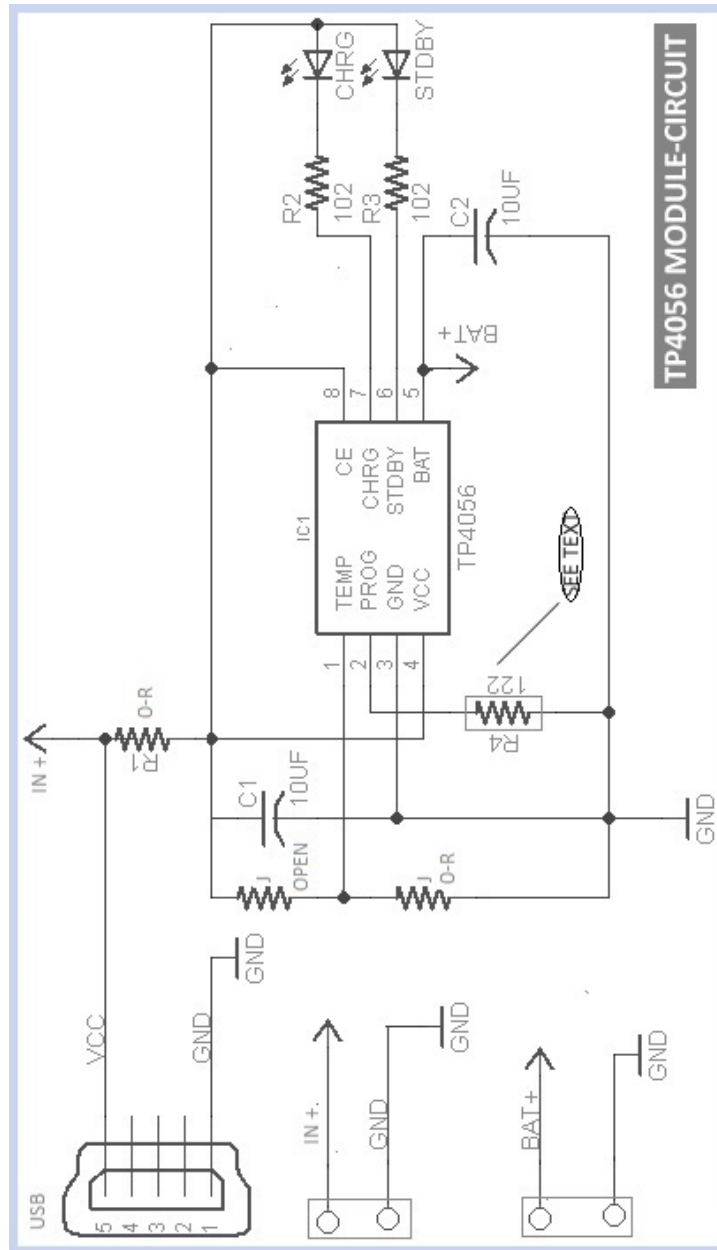

SKEMATIK RANGKAIAN MODUL SD CARD

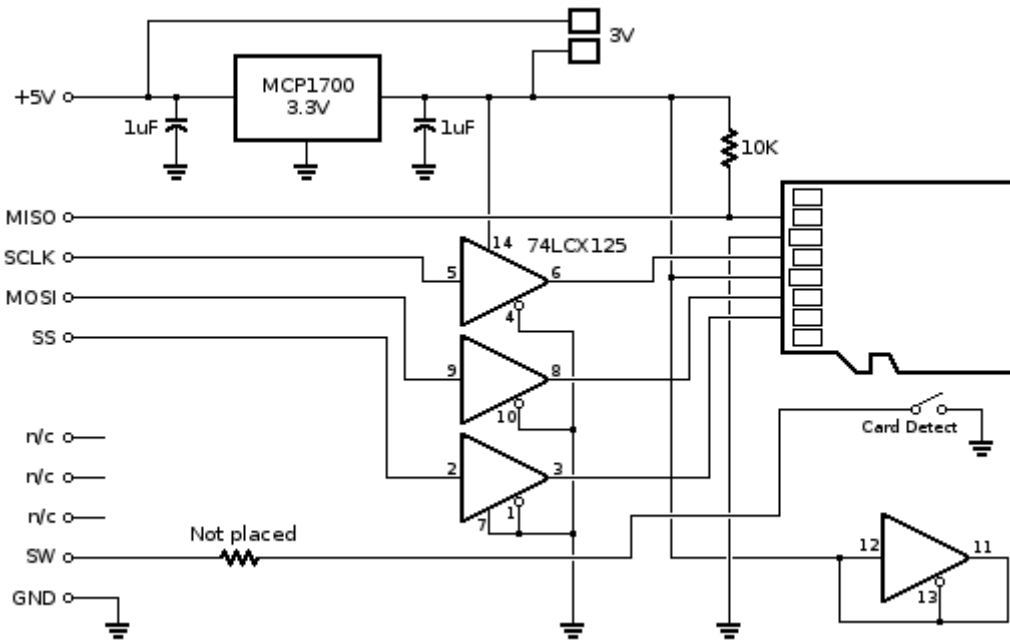

SKEMATIK RANGKAIAN PENGKONDISI SINYAL

