

# LAMPIRAN

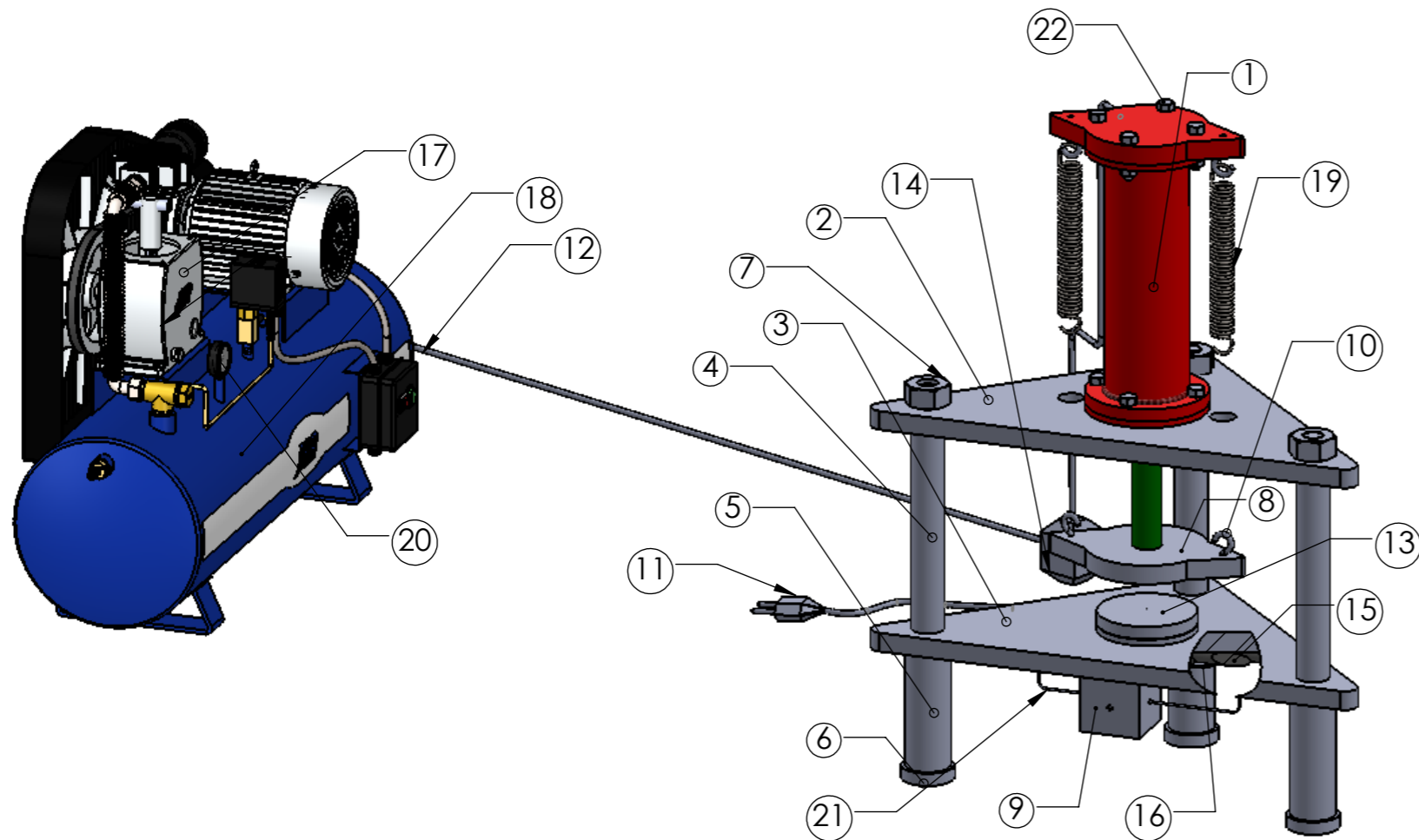

No	Jml	Nama Bagian	Bahan	Standarisasi	Catatan
22	8	Bolt & nut JIS M4	ST 37		Item tersedia
21	1	Selang PVC	PVC		Item tersedia
20	1	Pressure gauge	Generic		Item tersedia
19	2	Pegas tarik	SUS 401		
18	1	Tangki kompresor	Generic		Item tersedia
17	1	Piston kompresor	Generic		Item tersedia
16	2	Klem	Galvanic		
15	3	Tubular heater	Stainless		Item tersedia
14	1	Katup kontrol arah 3/2	Generic		Item tersedia
13	2	Mold	S45C		
12	1	Tubbing	Polyurethane		Item tersedia
11	1	Jack & Kabel	Generic		Item tersedia
10	4	Hook	Cast Iron		
9	1	Thermostat bimetal	Generic		Item tersedia
8	1	Plat tekan	S35C		
7	3	Mur JIS St 37	ST 37		Item tersedia
6	3	Spull	Steel		
5	3	Silinder kaki	Steel		
4	3	Poros kaki	Steel		
3	1	Plat dasar	Steel		
2	1	Plat atas	Steel		
1	1	Pneumatik	Steel		

Kekerasan Permukaan $\mu\text{m}$	Toleransi Ukuran dalam $\mu\text{m}$		
	Satuan : mm	Digambar: Habibi	Peringatan
	Skala : 1:5	NIM: 20130130220	
	Tanggal : 17-08-17	Dilihat: Cahyo B. S.T., M.Sc.	

TEKNIK MESIN	MESIN COMPRESSION MOLDING	No 1	A3
--------------	---------------------------	------	----

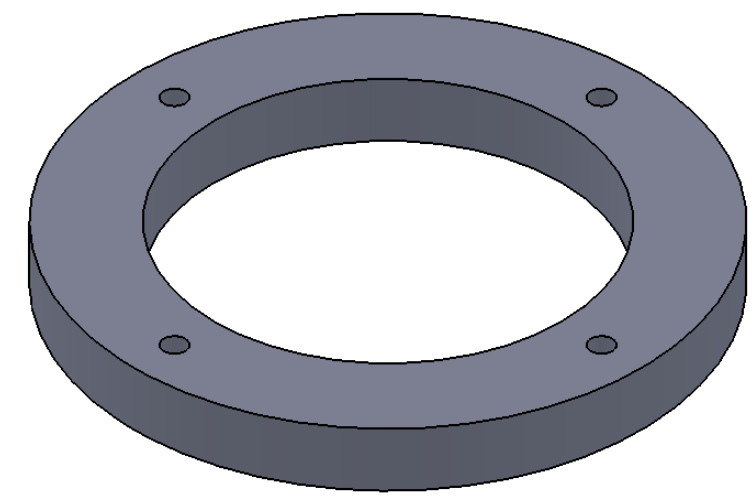
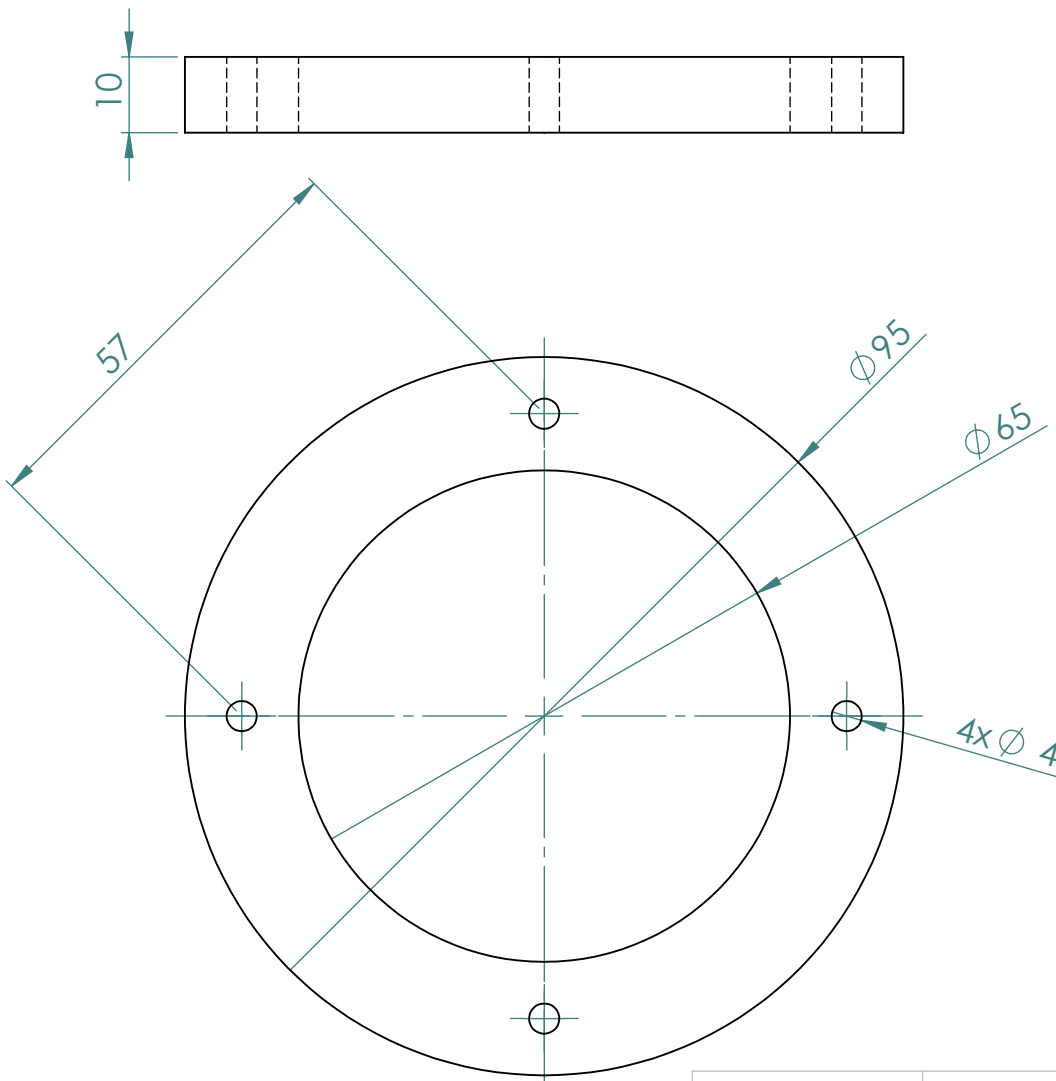

	Satuan : mm	Digambar : HABIBI	Peringatan	
	Skala : 1:1	NIM : 20130130220		
	Tanggal : 17-08-17	Dilihat : Cahyo B. S.T., M.Sc.		
TEKNIK MESIN	Bibir Silinder Atas		1.1.1	A4

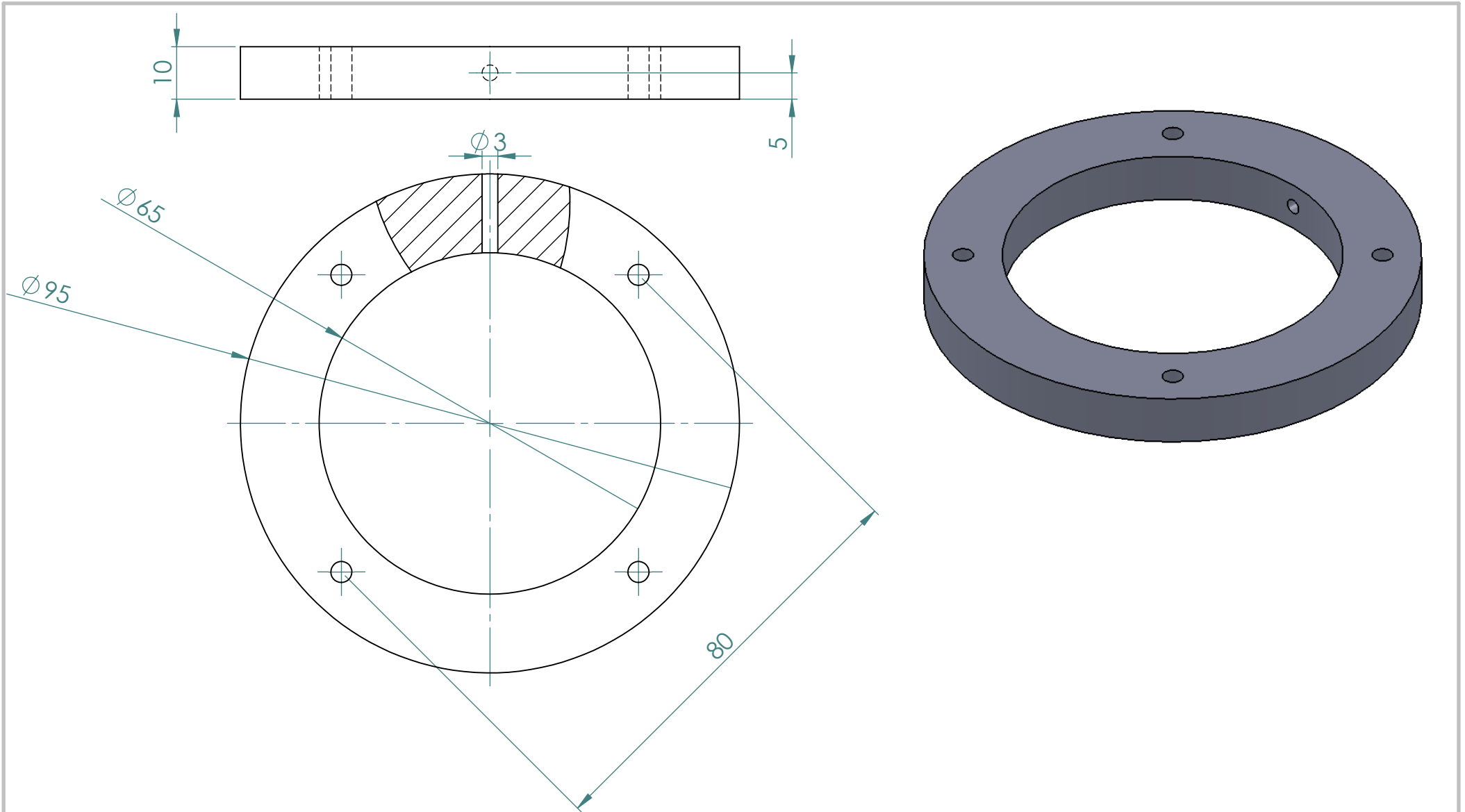

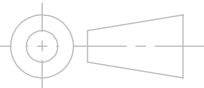
	Satuan : mm	Digambar : HABIBI	Peringatan	
	Skala : 1:1	NIM : 20130130220		
	Tanggal : 17-08-17	Dilihat : Cahyo B. S.T., M.Sc.		
TEKNIK MESIN	Bibir Silinder Bawah		1.1.2	A4

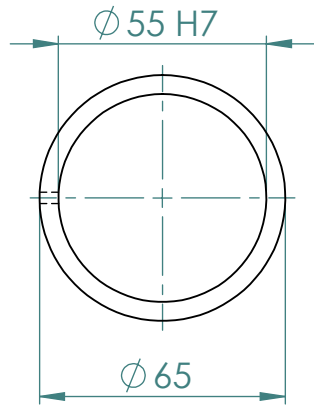
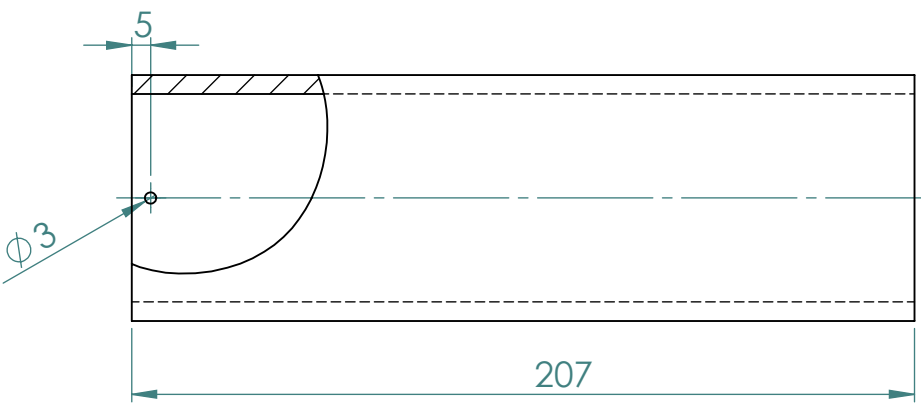
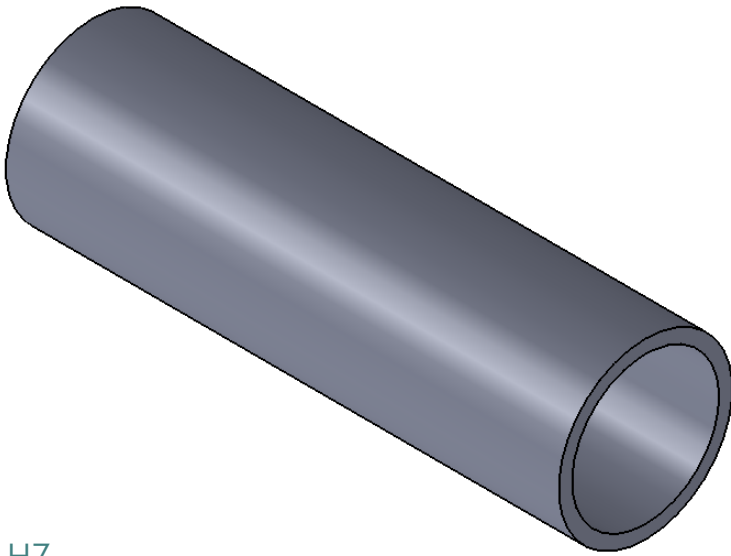

	Satuan : mm	Digambar : HABIBI	Peringatan	
	Skala : 1:2	NIM : 20130130220		
	Tanggal : 17-08-17	Dilihat : Cahyo B. S.T., M.Sc.		
TEKNIK MESIN	Silinder		1.1.3	A4

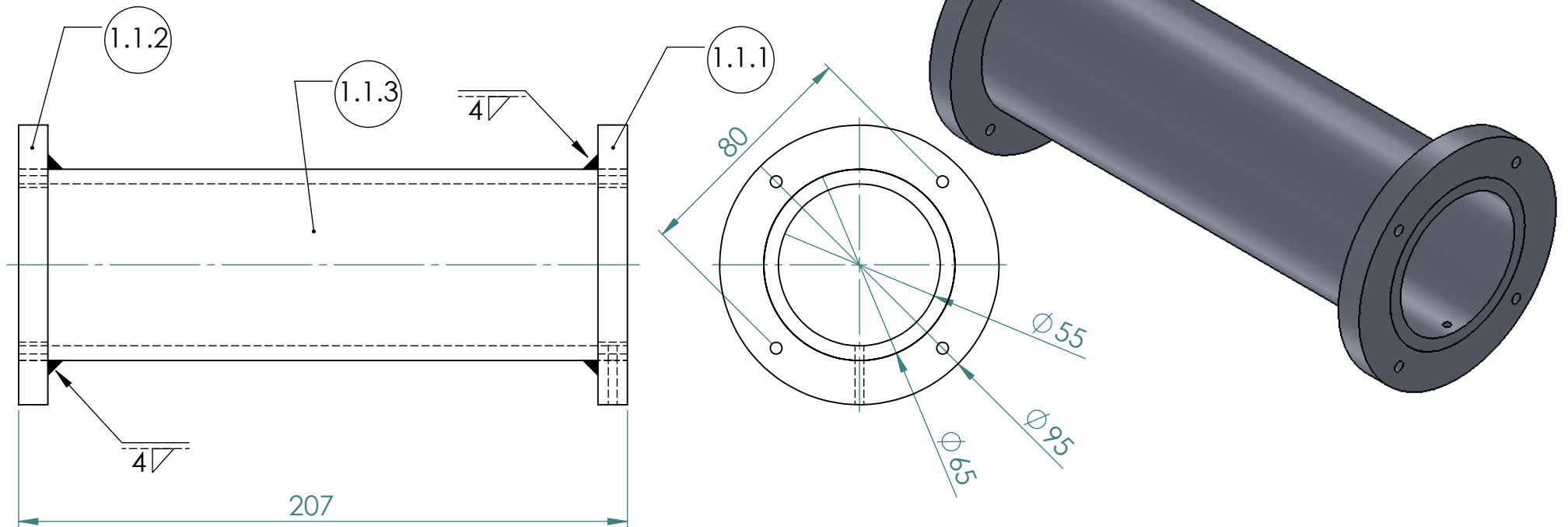

1.1.3	1	Silinder	ST42		
1.1.2	1	Bibir silinder bawah	Steel		
1.1.1	1	Bibir silinder atas	Steel		
No	Jml	Nama Bagian	Bahan	Standarisasi	Catatan
Kekerasan Permukaan $\mu\text{m}$		Toleransi Ukuran dalam $\mu\text{m}$			
		Satuan : mm	Digambar : HABIBI		Peringatan
		Skala : 1:2	NIM : 20130130220		
		Tanggal : 17-08-17	Dilihat : Cahyo B. S.T., M.Sc.		
TEKNIK MESIN			ASSEMBLY SILINDER PNEUMATIK		1.1
					A4

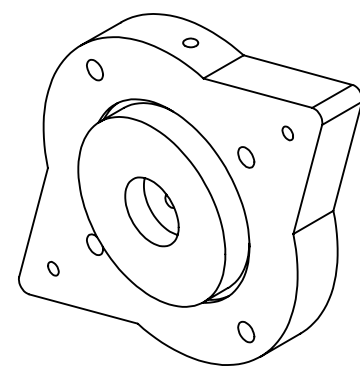
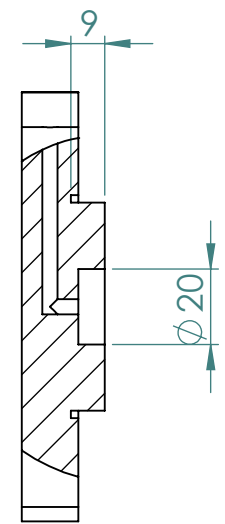
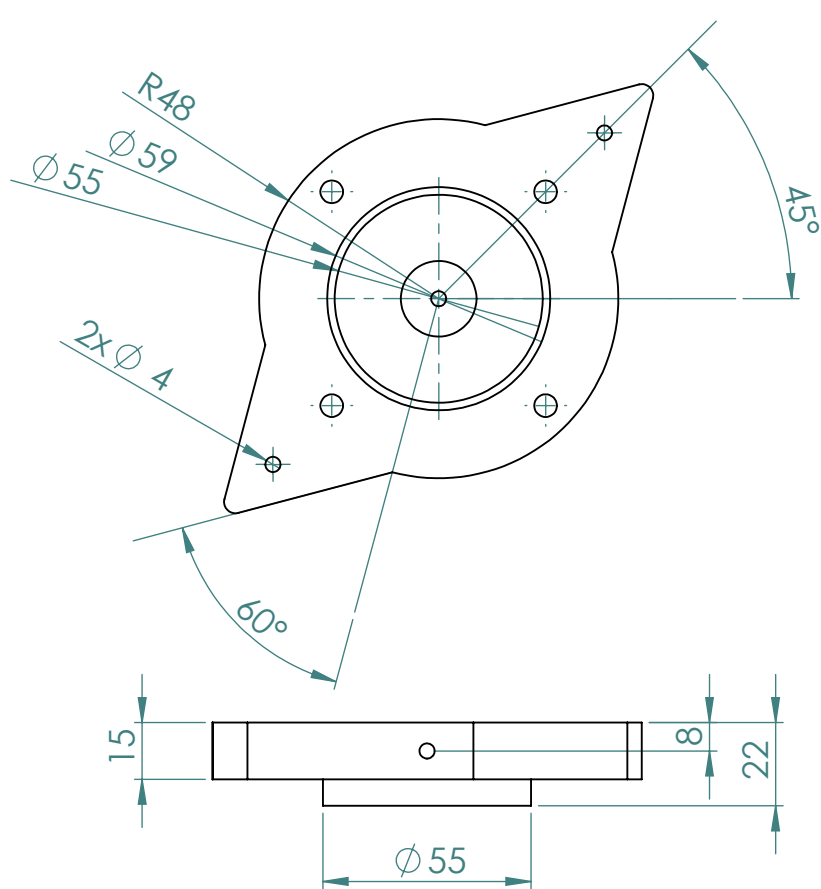

	Satuan : mm	Digambar : HABIBI	Peringatan	
	Skala : 1:2	NIM : 20130130220		
	Tanggal : 17-08-17	Dilihat : Cahyo B. S.T., M.Sc.		
TEKNIK MESIN	Tutup Atas Pneumatik		1.3	A4

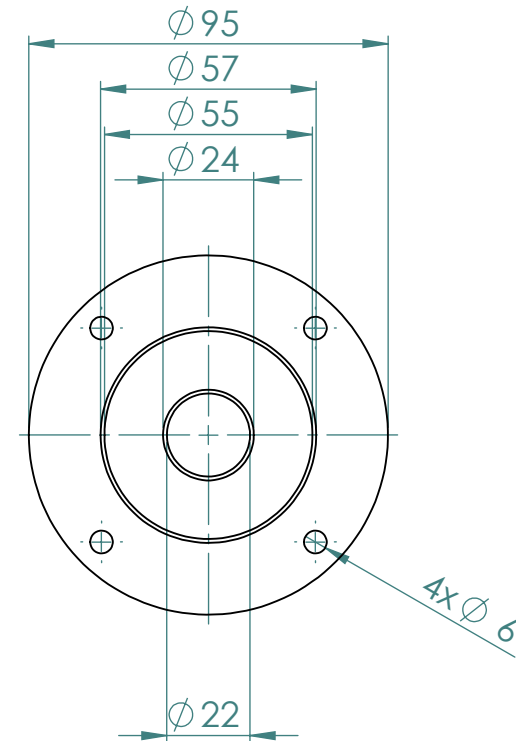
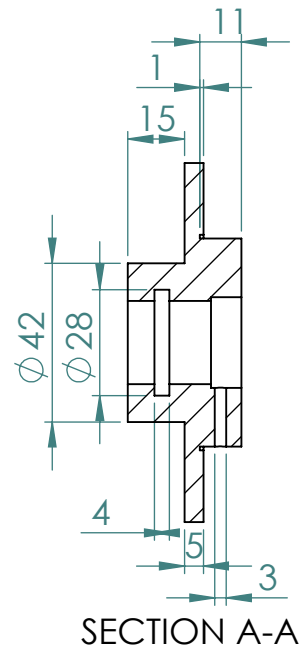
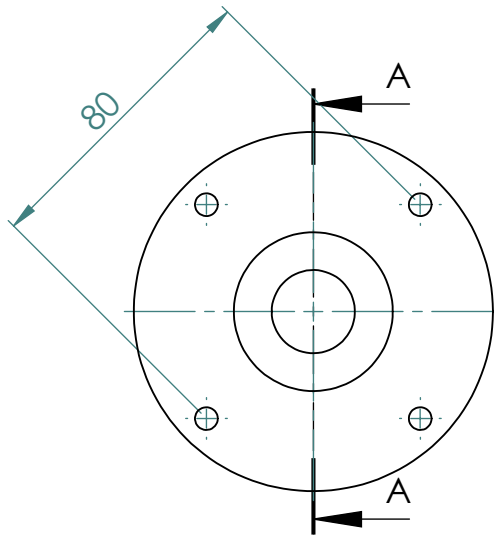

	Satuan : mm	Digambar : HABIBI	Peringatan	
	Skala : 1:2	NIM : 20130130220		
	Tanggal : 17-08-17	Dilihat : Cahyo B. S.T., M.Sc.		
TEKNIK MESIN	Tutup Bawah Pneumatik		1.2	A4



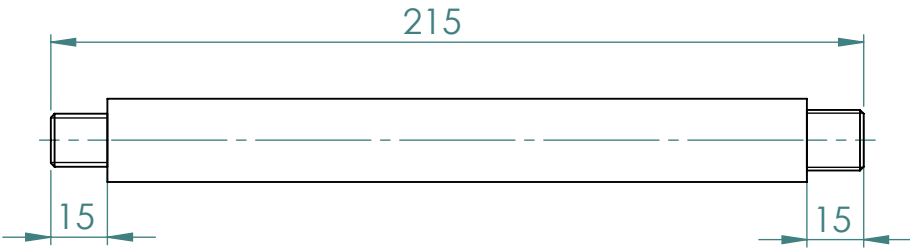
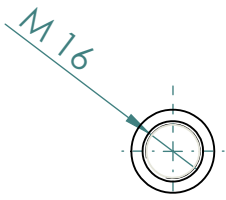
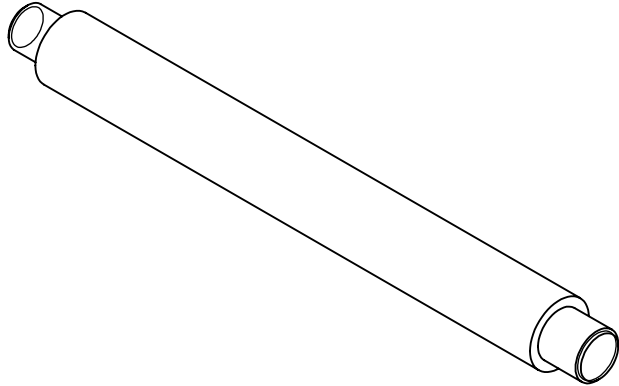

	Satuan : mm	Digambar : HABIBI	Peringatan	
	Skala : 1:2	NIM : 20130130220		
	Tanggal : 17-08-17	Dilihat : Cahyo B. S.T., M.Sc.		
TEKNIK MESIN	Rod Piston		1.5	A4

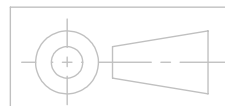
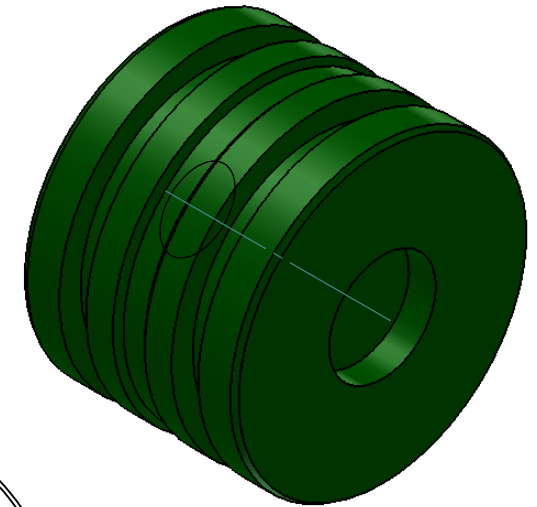
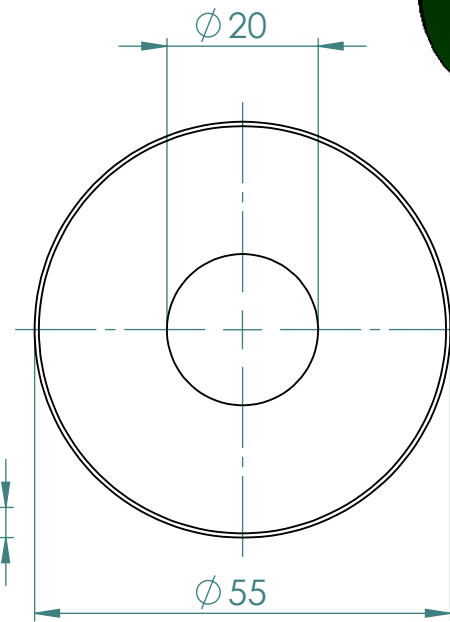
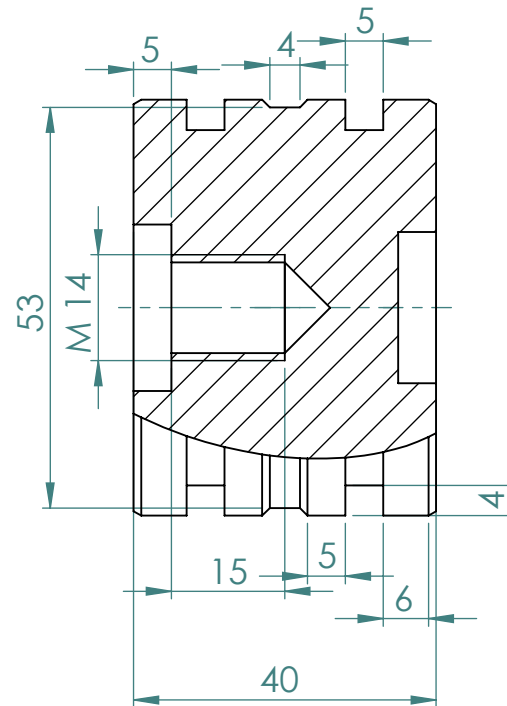
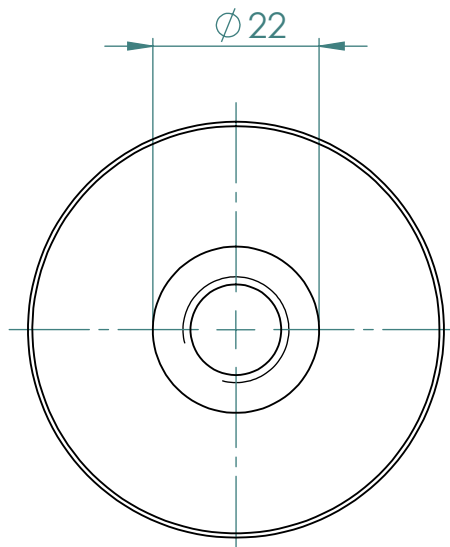

Satuan : mm  
 Skala : 1:2  
 Tanggal : 17-08-17

Digambar : HABIBI  
 NIM : 20130130220  
 Dilihat : Cahyo B. S.T., M.Sc.

Peringatan

TEKNIK MESIN

Piston

1.5

A4

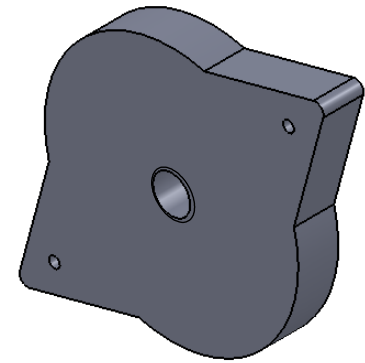
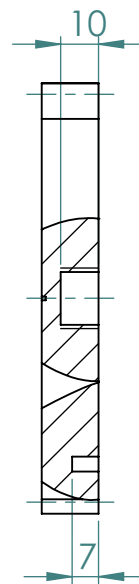
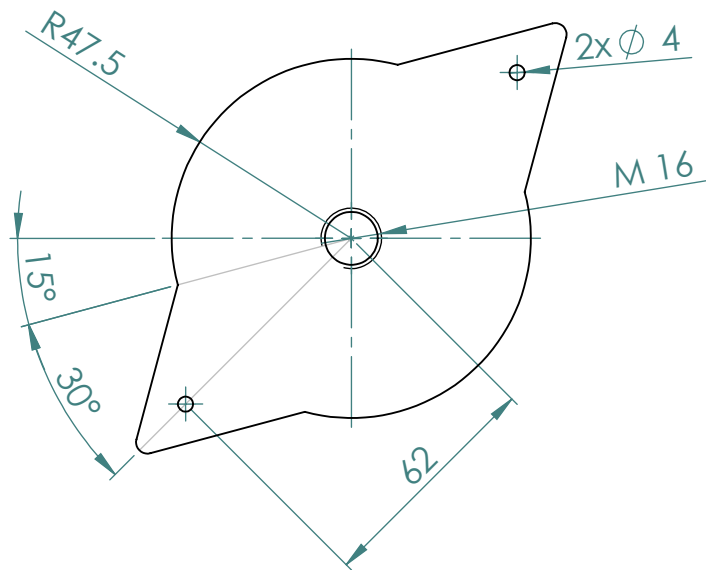

	Satuan : mm	Digambar : HABIBI	Peringatan	
	Skala : 1:2	NIM : 20130130220		
	Tanggal : 17-08-17	Dilihat : Cahyo B. S.T., M.Sc		
TEKNIK MESIN	Plat Tekan		No. 08	A4

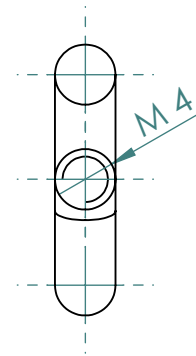
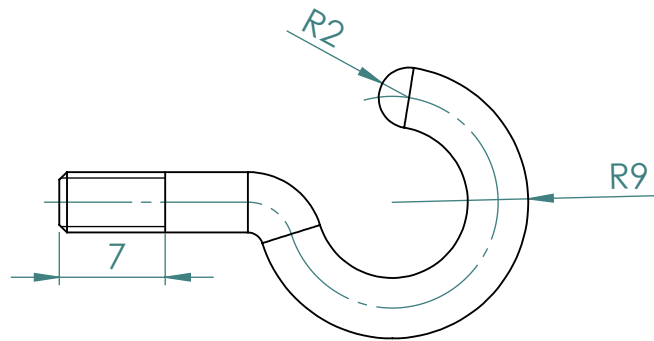
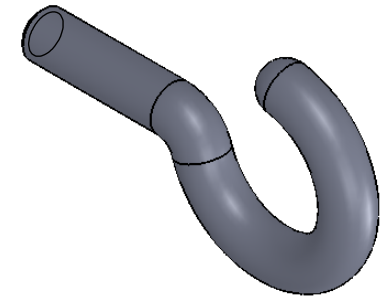
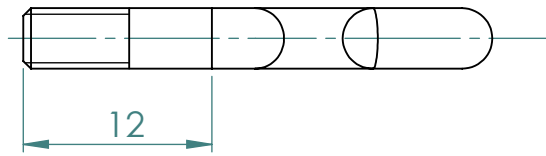

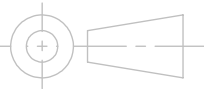
	Satuan : mm	Digambar : HABIBI	Peringatan	
	Skala : 2:1	NIM : 20130130220		
	Tanggal : 17-08-17	Dilihat : Cahyo B. S.T., M.Sc		
TEKNIK MESIN	Hook		No. 10	A4

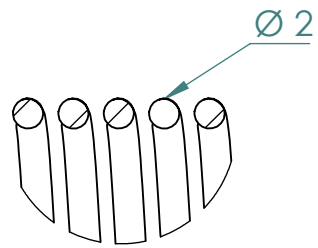

DETAIL A  
SCALE 2 : 1

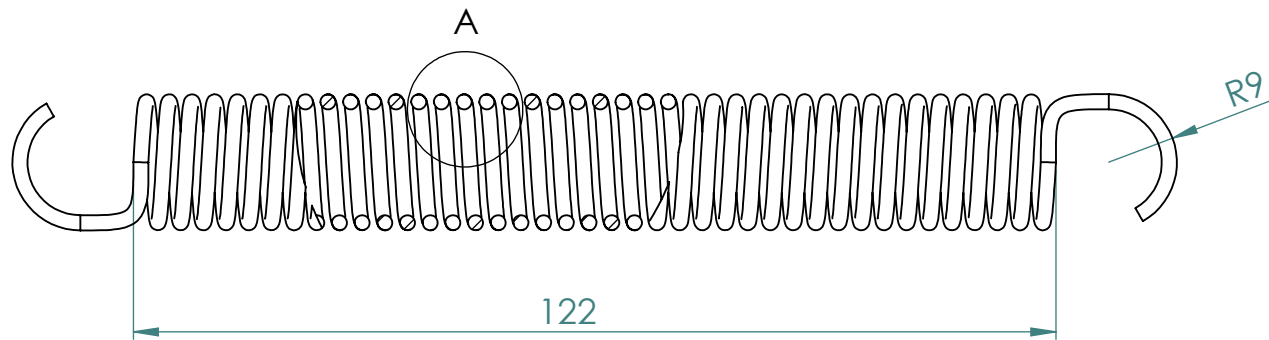
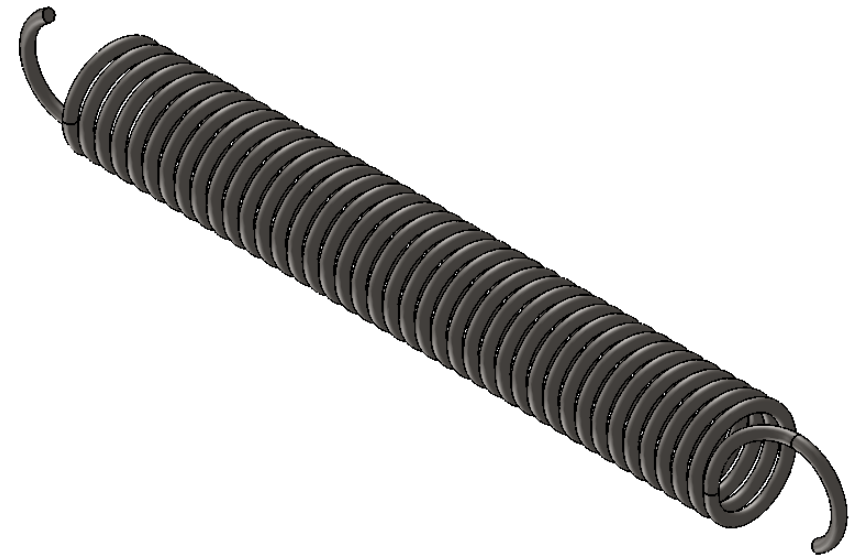

	Satuan : mm	Digambar : HABIBI	Peringatan	
	Skala : 1:1	NIM : 20130130220		
	Tanggal : 17-08-17	Dilihat : Cahyo B. S.T., M.Sc		
TEKNIK MESIN	Pegas Tarik		No. 22	A4

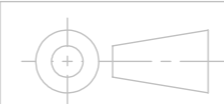
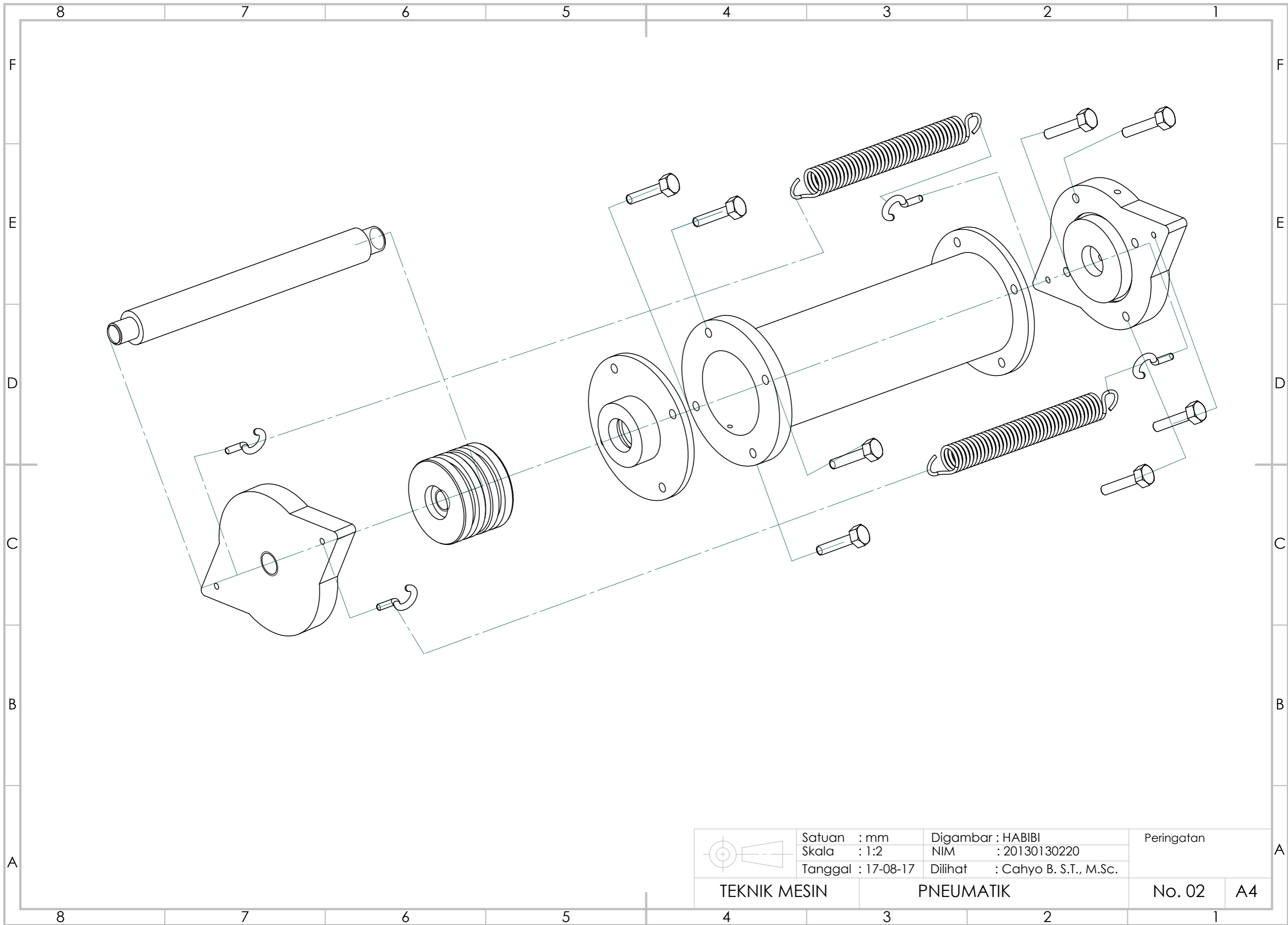

Satuan : mm  
 Skala : 1:2  
 Tanggal : 17-08-17

Digambar : HABIBI  
 NIM : 20130130220  
 Dilihat : Cahyo B. S.T., M.Sc.

Peringatan

TEKNIK MESIN	PNEUMATIK	No. 02	A4
--------------	-----------	--------	----

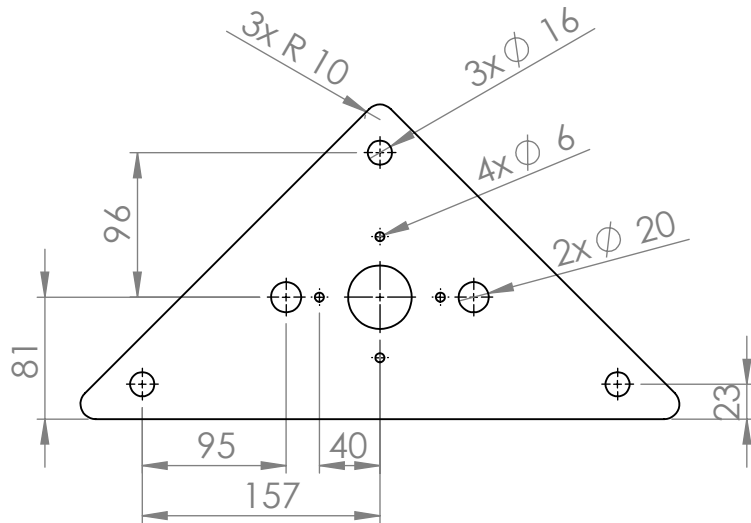
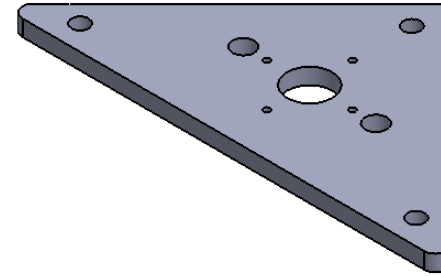

	Satuan : mm	Digambar : HABIBI	Peringatan	
	Skala : 1:5	NIM : 20130130220		
	Tanggal : 17-08-17	Dilihat : Cahyo B. S.T., M.Sc.		
TEKNIK MESIN	Plat Atas		No. 02	A4

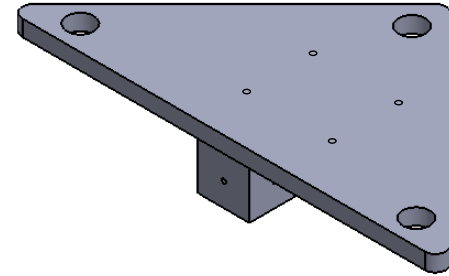
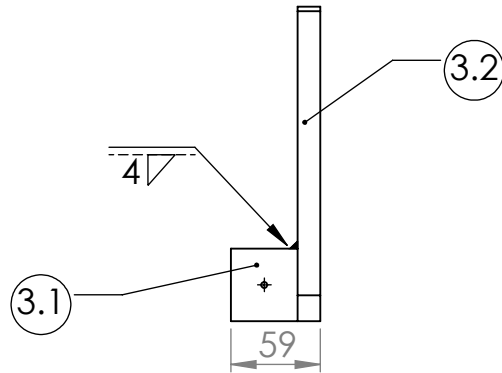
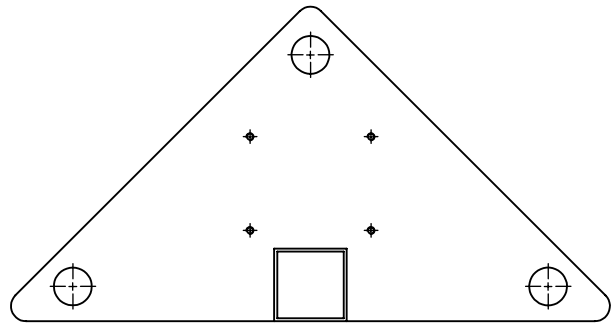
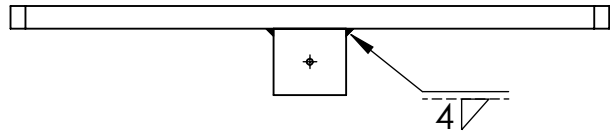

3.2	1	Plat Heater	Steel		
3.1	1	Box Bimetal	Steel		
No	Jml	Nama Bagian	Bahan	Standarisasi	Catatan
Kekerasan Permukaan $\mu\text{m}$		Toleransi Ukuran dalam $\mu\text{m}$			
		Satuan : mm	Digambar : HABIBI		Peringatan
		Skala : 1:5	NIM : 20130130220		
		Tanggal : 17-08-17	Dilihat : Cahyo B. S.T., M.Sc.		
TEKNIK MESIN			Assembly Plat Bawah		No. 04   A4



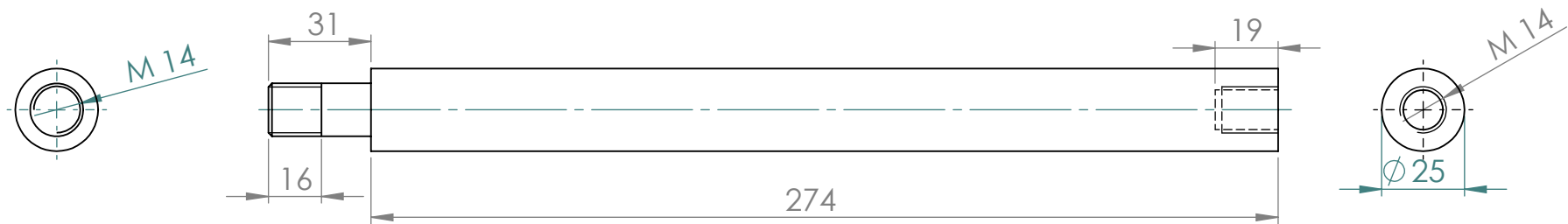
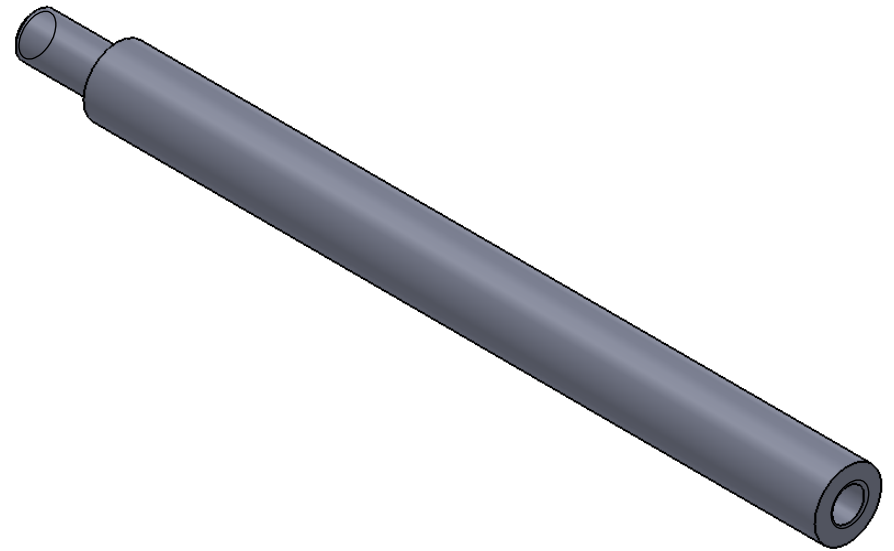

	Satuan : mm	Digambar : HABIBI	Peringatan	
	Skala : 1: 2	NIM : 20130130220		
	Tanggal : 17-08-17	Dilihat : Cahyo B. S.T., M.Sc.		
TEKNIK MESIN	Rod Kaki		No. 05	A4

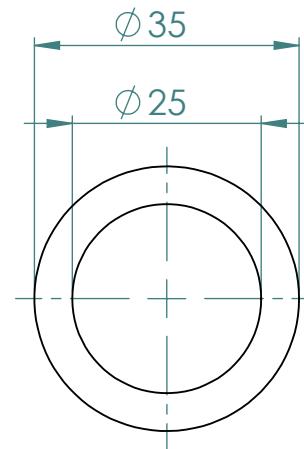
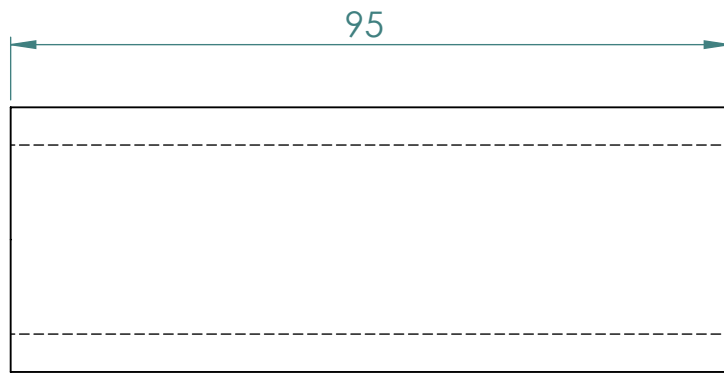
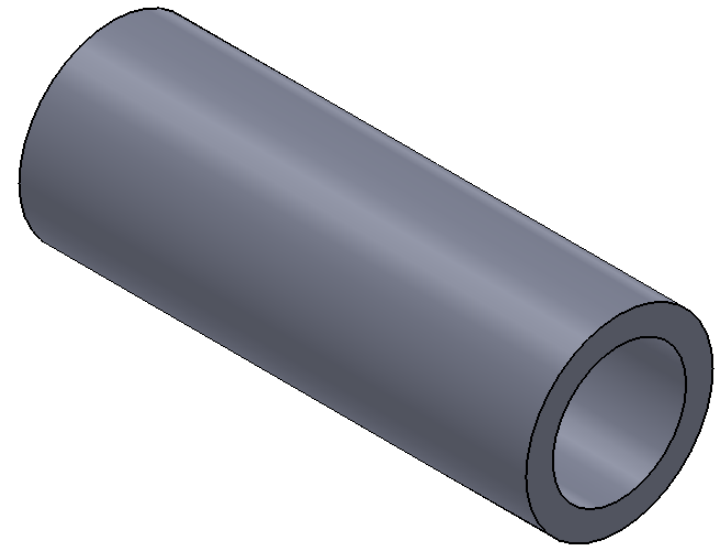

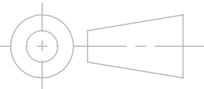
	Satuan : mm	Digambar : HABIBI	Peringatan	
	Skala : 1:1	NIM : 20130130220		
	Tanggal : 17-08-17	Dilihat : Cahyo B. S.T., M.Sc.		
TEKNIK MESIN	BOSS		No. 02	A4

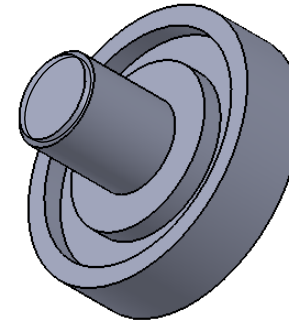
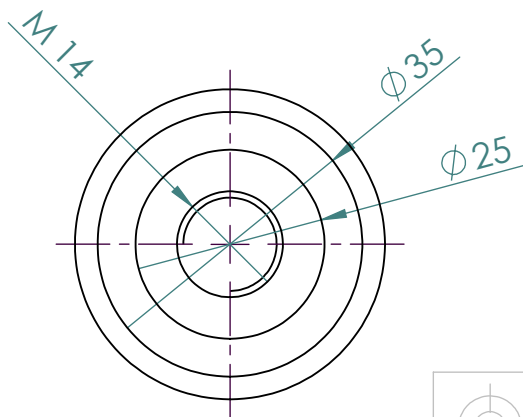
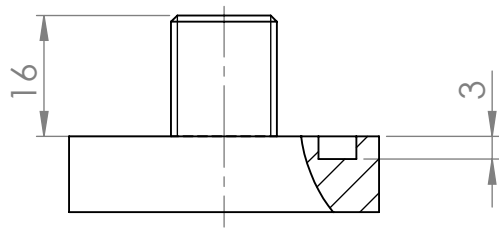
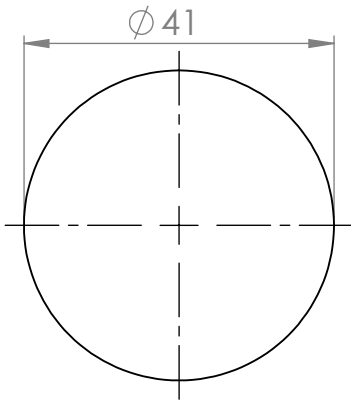

	Satuan : mm	Digambar : HABIBI	Peringatan	
	Skala : 1:1	NIM : 20130130220		
	Tanggal : 17-08-17	Dilihat : Cahyo B. S.T., M.Sc.		
TEKNIK MESIN	Spull		No. 06	A4

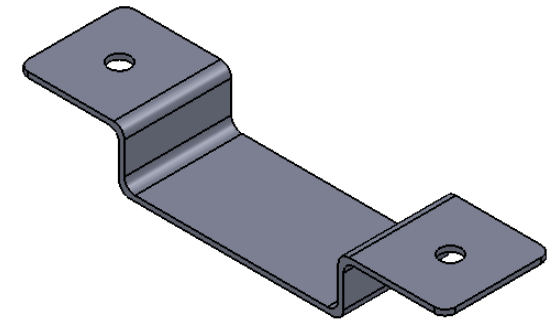
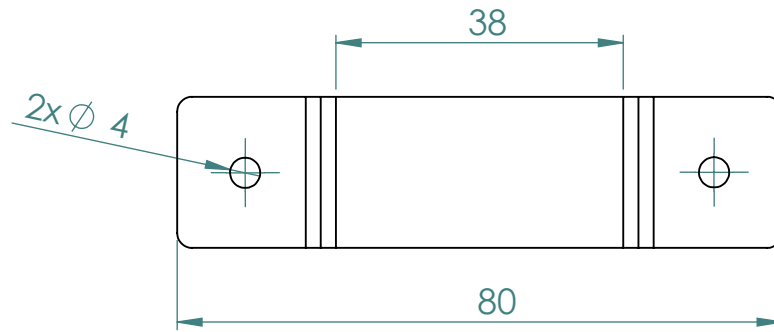

	Satuan : mm	Digambar : HABIBI	Peringatan	
	Skala : 1:1	NIM : 20130130220		
	Tanggal : 17-08-17	Dilihat : Cahyo B. S.T., M.Sc.		
TEKNIK MESIN	Klem		No. 16	A4

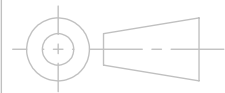
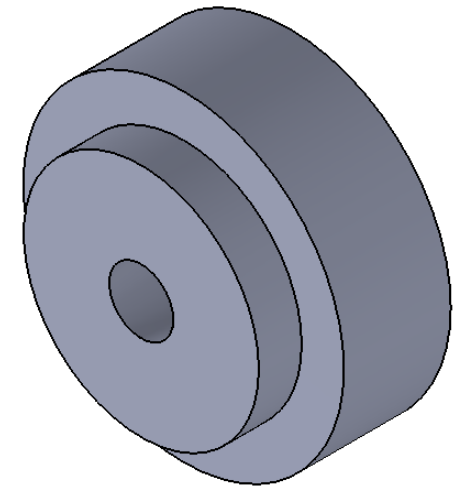
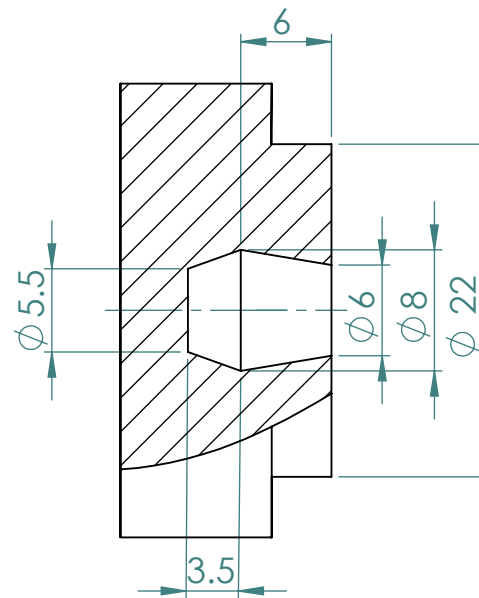
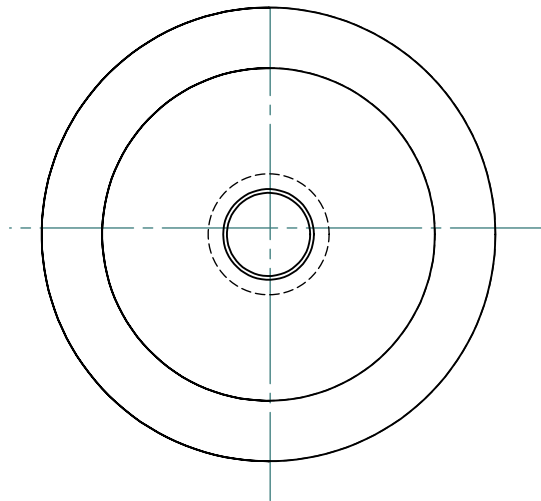
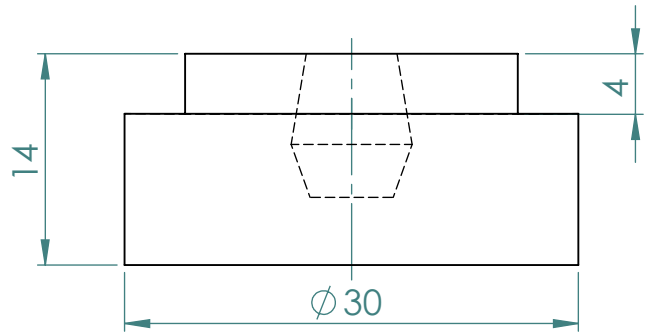

Satuan : mm  
 Skala : 2:1  
 Tanggal : 17-08-17

Digambar : HABIBI  
 NIM : 20130130220  
 Dilihat : Cahyo B. S.T., M.Sc.

Peringatan

TEKNIK MESIN

Down Plate Mold

No. 14

A4

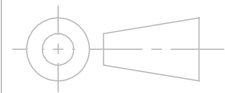
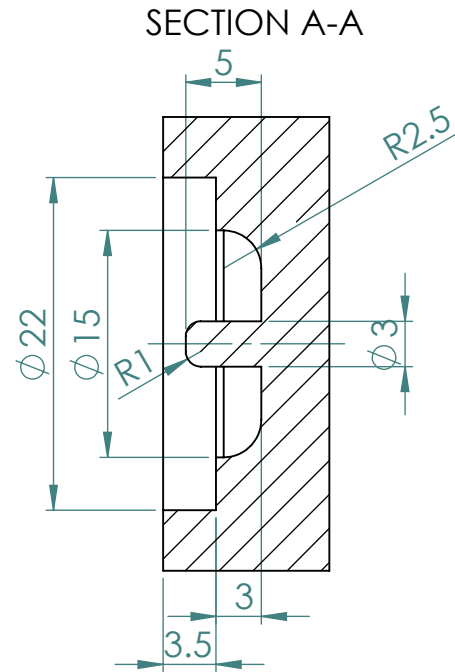
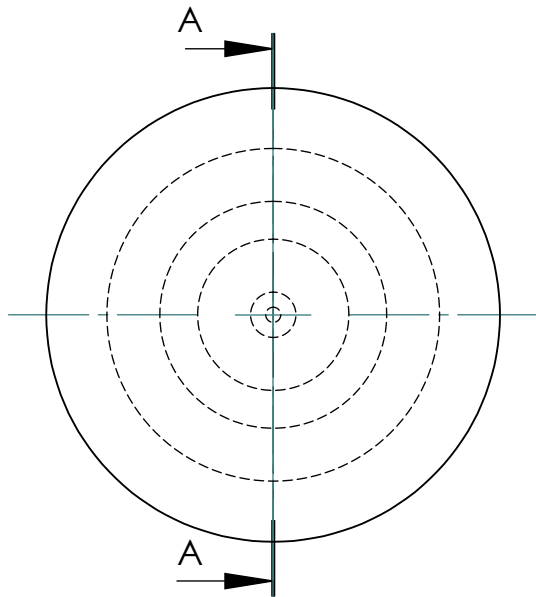
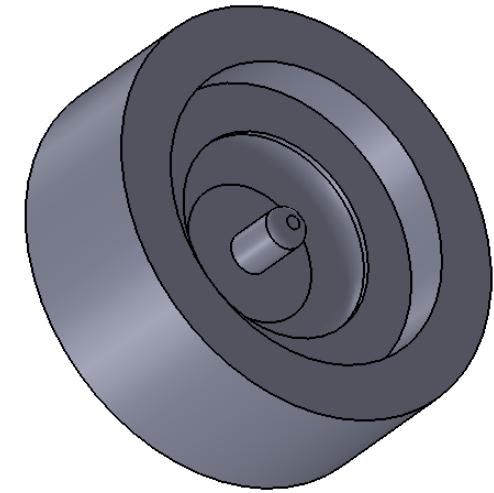
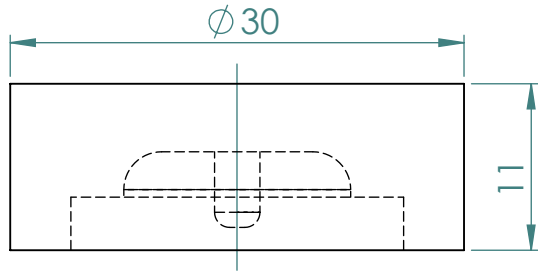

Satuan : mm  
 Skala : 2:1  
 Tanggal : 17-08-17

Digambar : HABIBI  
 NIM : 20130130220  
 Dilihat : Cahyo B. S.T., M.Sc.

Peringatan

TEKNIK MESIN

Up Plate Mold

No. 13

A4

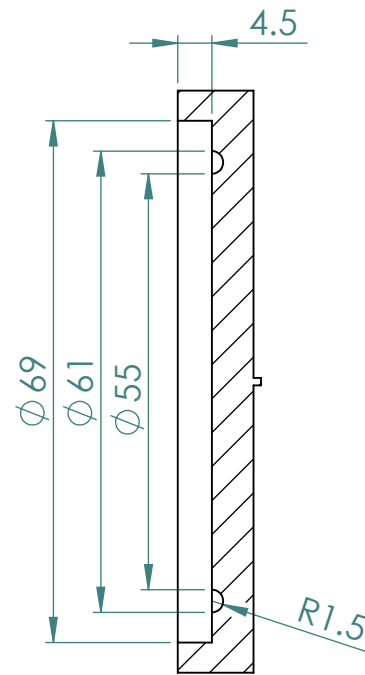
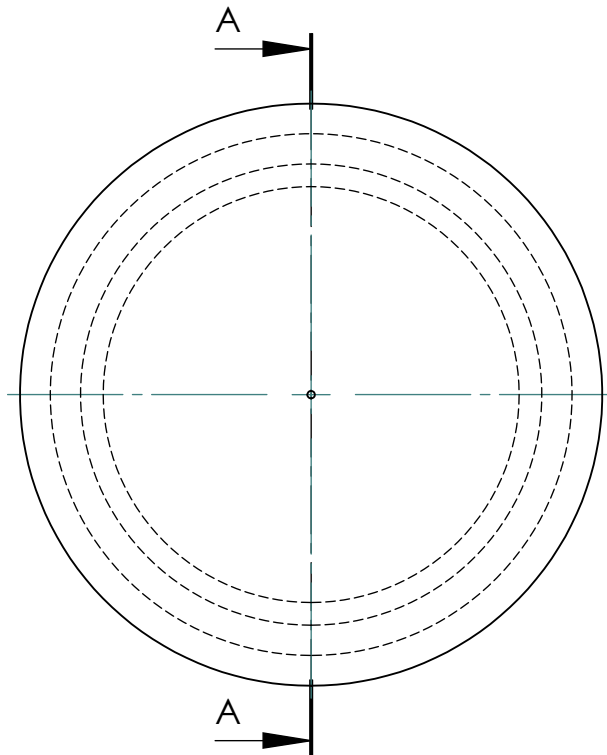
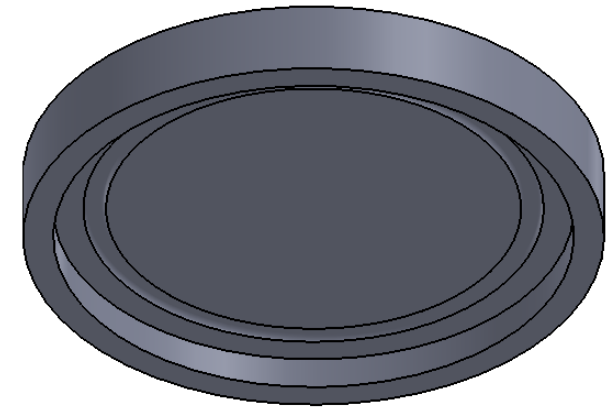
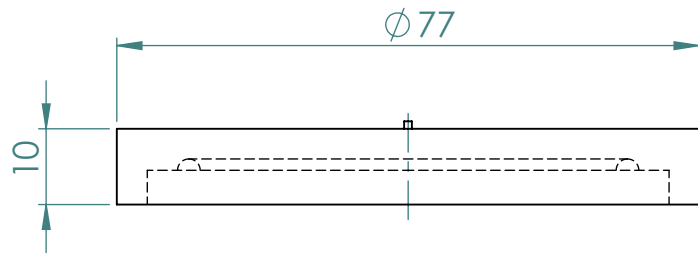

SECTION A-A

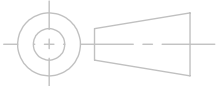
	Satuan : mm	Digambar : HABIBI	Peringatan	
	Skala : 1:1	NIM : 20130130220		
	Tanggal : 17-08-17	Dilihat : Cahyo B. S.T., M.Sc		
TEKNIK MESIN	Mold Male O-Ring		No. 13	A4

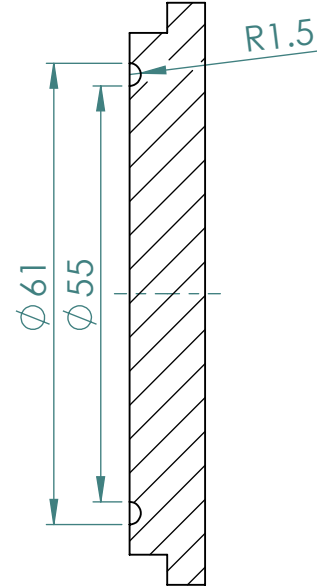
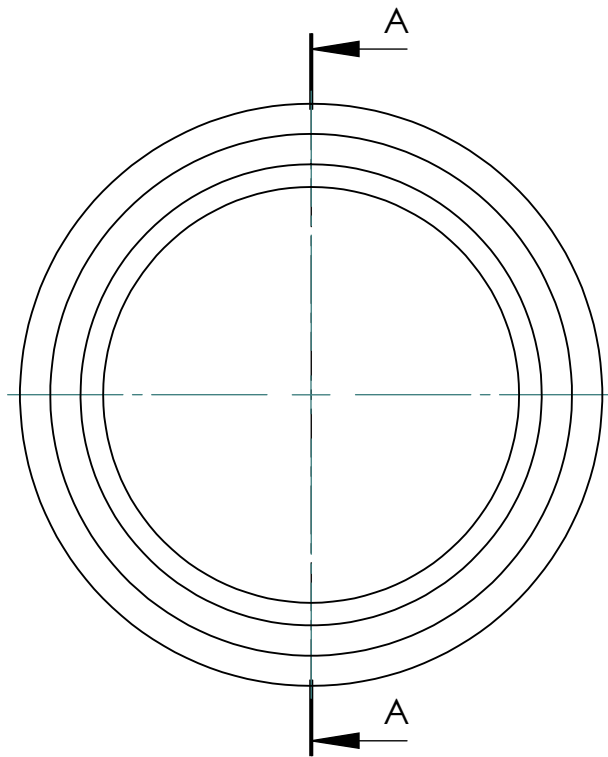
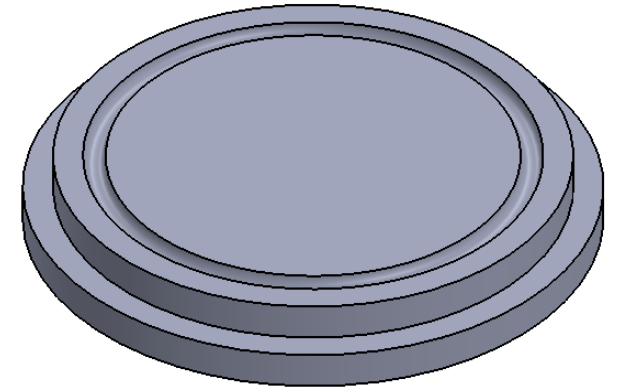
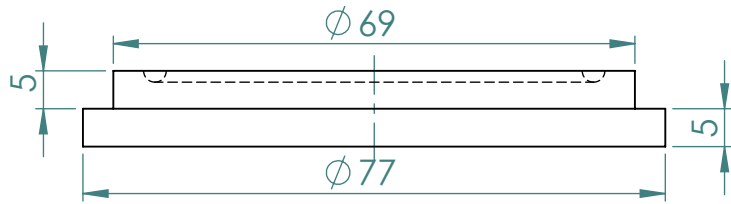

SECTION A-A

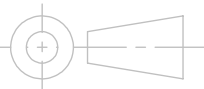
	Satuan : mm	Digambar : HABIBI	Peringatan	
	Skala : 1:1	NIM : 20130130220		
	Tanggal : 17-08-17	Dilihat : Cahyo B. S.T., M.Sc		
TEKNIK MESIN	Mold Female O-Ring		No. 14	A4



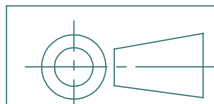
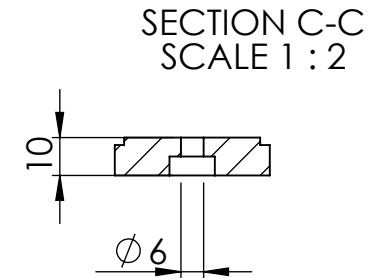
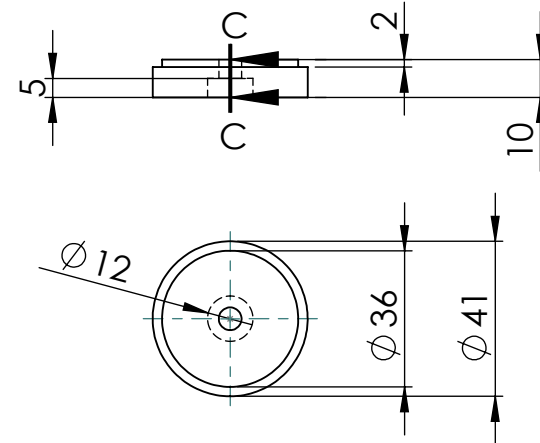
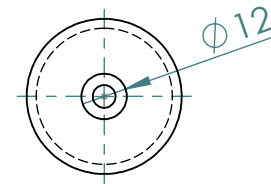
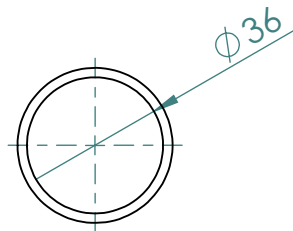
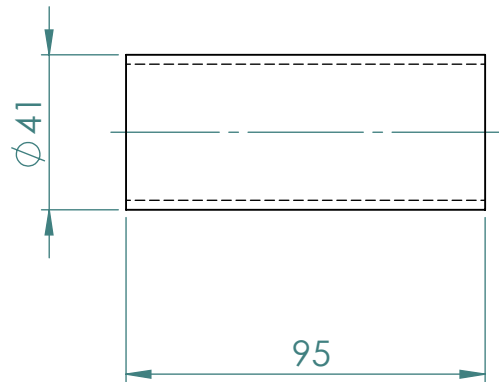
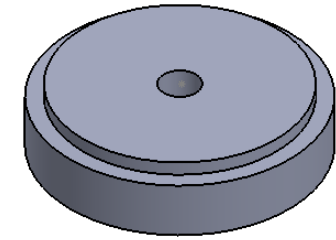
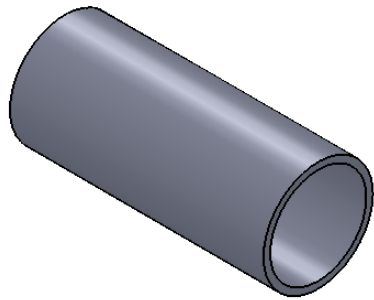

Satuan : mm  
Skala : 1:2  
Tanggal : 28-12-2017

Digambar : Diego Maryanto  
NIM : 20130130211  
Dilihat : Cahyo B. S.T., M.Sc

Peringatan

TEKNIK MESIN

KAKI RANGKA DAN SPULL

No. 01

A4

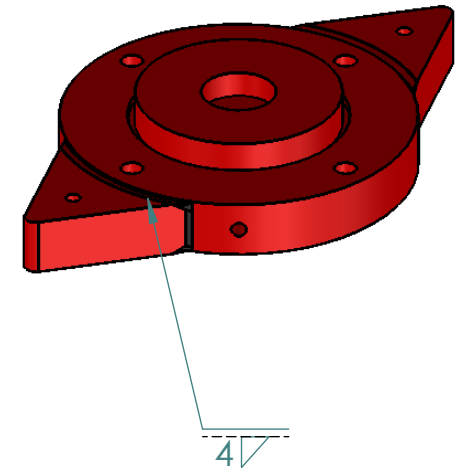
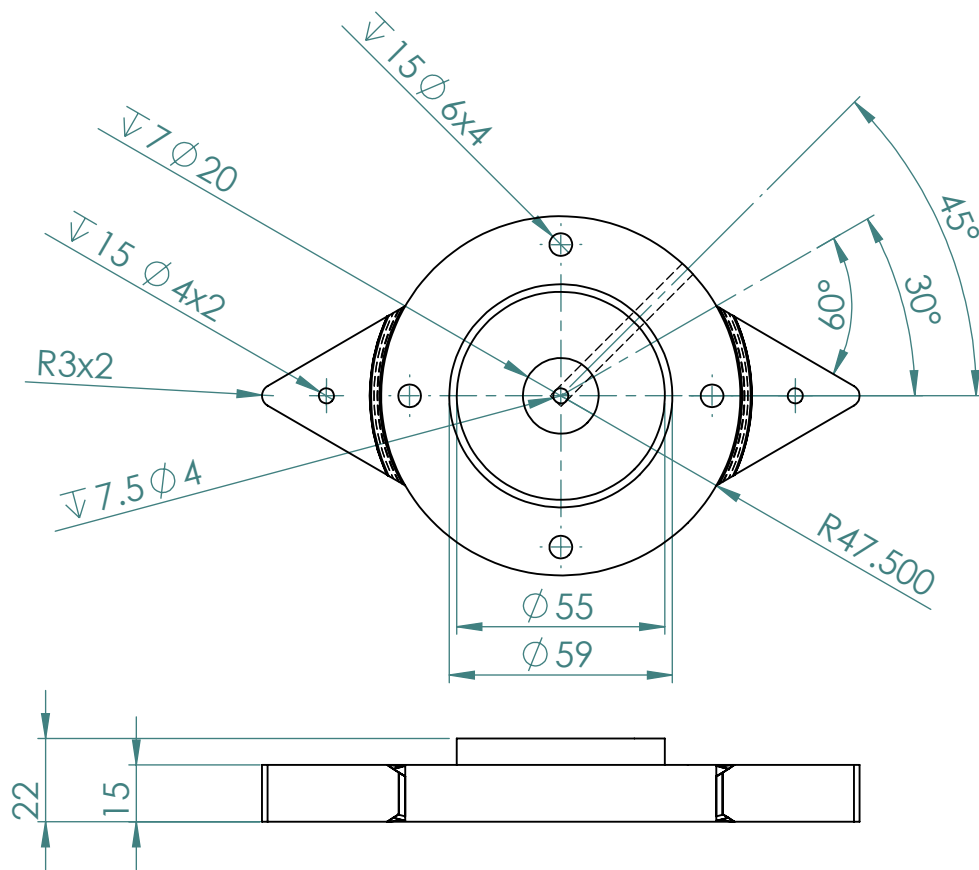

	Satuan : mm	Digambar : Diego Maryanto	Peringatan	
	Skala : 1 : 2	NIM : 20130130211		
	Tanggal : 27-12-2017	Dilihat : Cahyo B. S.T., M.Sc		
TEKNIK MESIN	TUTUP ATAS PNEUMATIC		No. 02	A.4

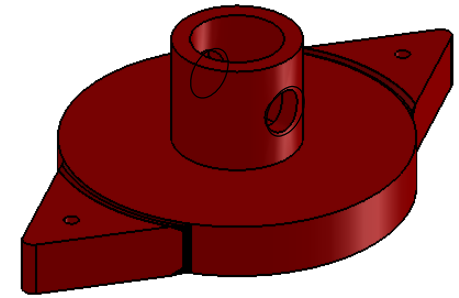
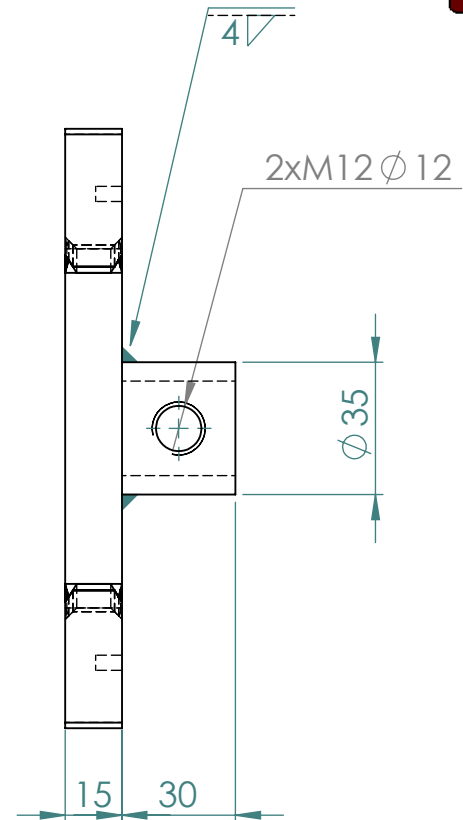
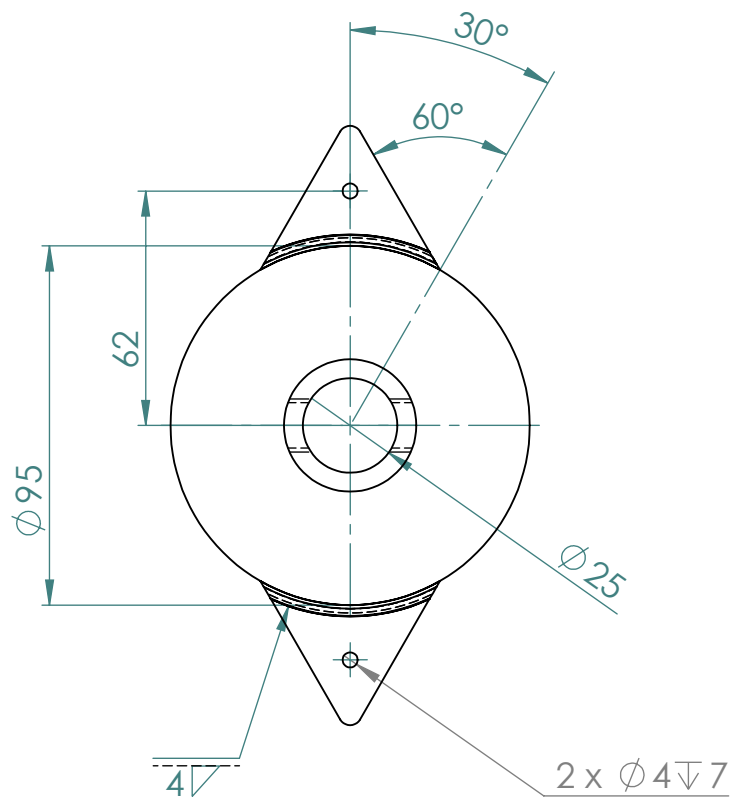

	Satuan : mm	Digambar : Diego Maryanto	Peringatan	
	Skala : 1 : 2	NIM : 20130130211		
	Tanggal : 27-12-2017	Dilihat : Cahyo B. S.T., M.Sc		
TEKNIK MESIN	PLAT TEKAN	No. 03	A4	

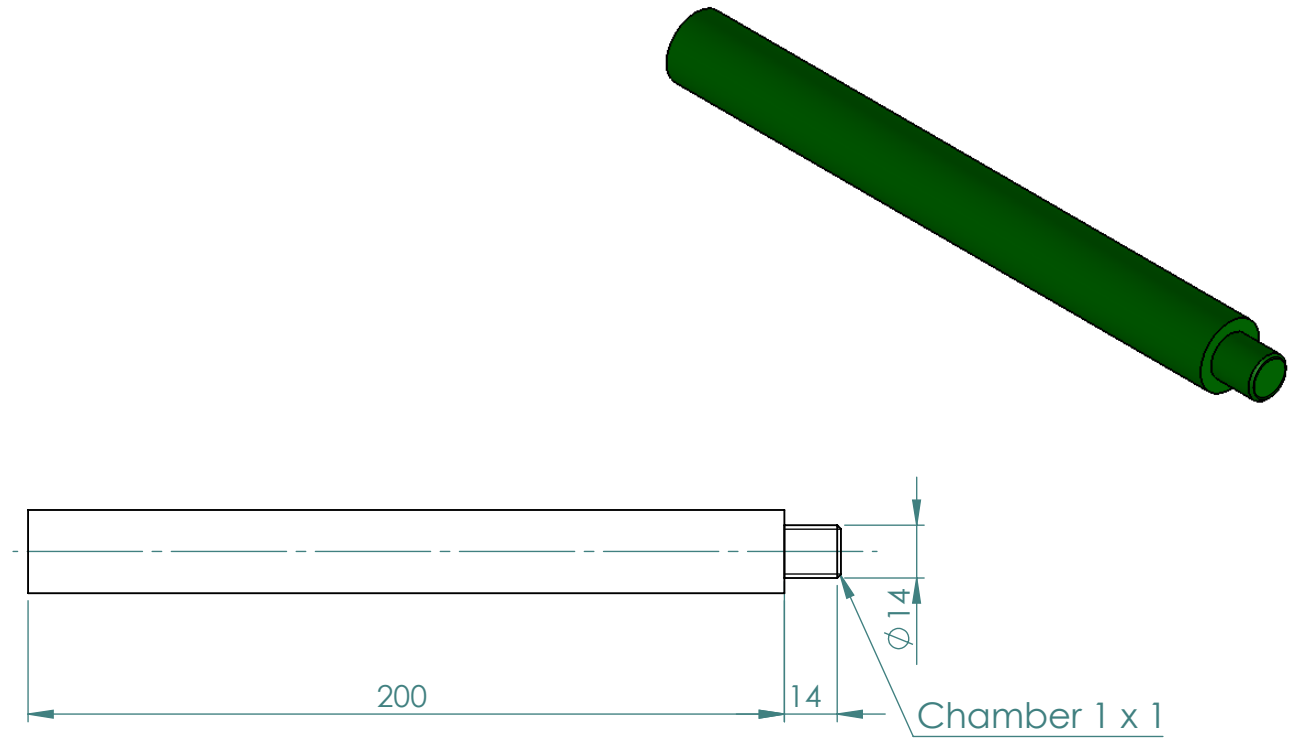
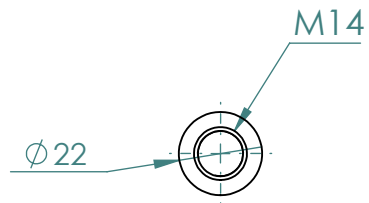

	Satuan : mm	Digambar : Diego Maryanto	Peringatan	
	Skala : 1:2	NIM : 20130130211		
	Tanggal : 27-12-2017	Dilihat : Cahyo B. S.T., M.Sc		
TEKNIK MESIN	ROD PISTON		No. 04	A4

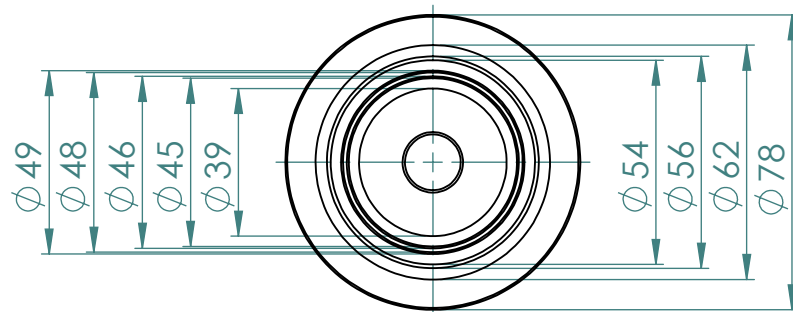
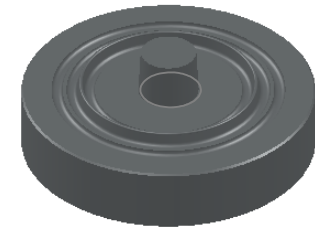
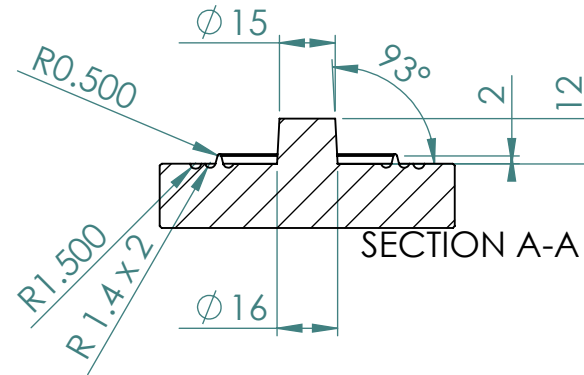
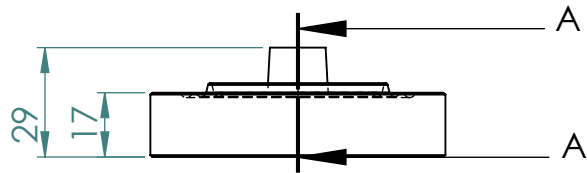

	Satuan : mm	Digambar : Diego Maryanto	Peringatan	
	Skala : 1: 2	NIM : 20130130211		
	Tanggal : 27-12-2017	Dilihat : Cahyo B. S.T., M.Sc		
TEKNIK MESIN	MOLD UP		No. 05	A4

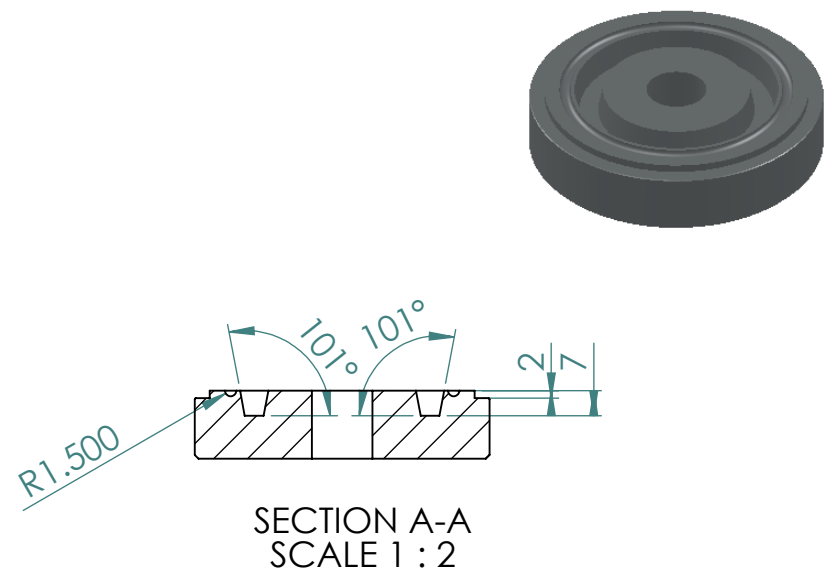
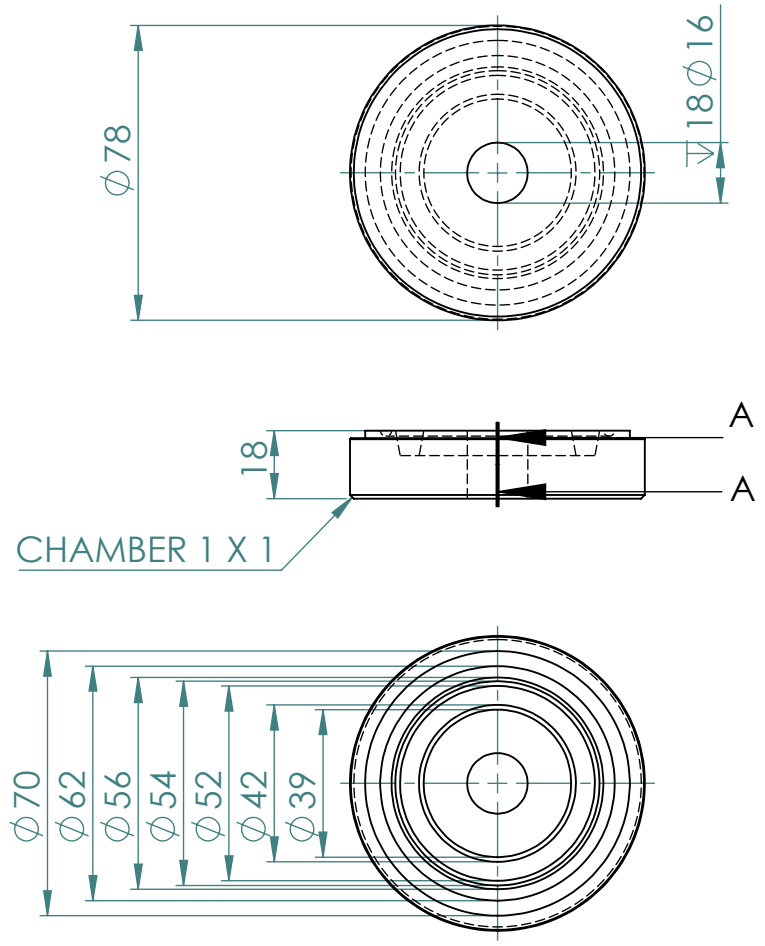

	Satuan : mm	Digambar : Diego Maryanto	Peringatan	
	Skala : 1 : 2	NIM : 20130130211		
	Tanggal : 27-12-2017	Dilihat : Cahyo B. S.T., M.Sc		
TEKNIK MESIN	MOLD DOWN		No. 06	A4