

# The Mediating Role of Perceived Organization Support on the Effect of Intrinsic and Extrinsic Rewards on Organizational Commitment among the Employees of Madukismo Sugar Factory Yogyakarta

Rina EkaWidjayanti<sup>1\*</sup> Siswoyo Haryono<sup>2</sup> Susanto<sup>3</sup>

1. Faculty of Economic and Business, Universitas Muhammadiyah Yogyakarta,  
Jl. Brawijaya, Bantul, Yogyakarta 55183

2. Post Graduate Studies, Universitas Muhammadiyah Yogyakarta  
Jl. Brawijaya, Bantul, Yogyakarta 55183

3. Master of Management, Universitas Muhammadiyah Yogyakarta  
Jl. Brawijaya, Bantul, Yogyakarta 55183

## Abstract

This study aims to identify the mediating role of perceived organizational support on the impact of intrinsic and extrinsic reward towards organizational commitment. The analysis unit of this study were employees of Madukismo Sugar Factory, Yogyakarta who had been working permanently for more than 15 years. Proportional random sampling was employed to collect the data of 210 respondents. Data is analyzed with SPSS 22.0 for descriptive analysis, and Analysis of Moment Structure (AMOS) version 22.0 for inferential analysis. The hypothesis testing results showed that intrinsic and extrinsic reward positively and significantly affect the perceived organization support. Intrinsic reward does not affect organizational commitment. Extrinsic reward and the perceived organizational support positively and significantly affect the organizational commitment. The perceived organizational support mediates the effect of intrinsic and extrinsic reward toward the organizational commitment.

**Keywords:** intrinsic reward, extrinsic reward, perceived organizational support, organizational commitment

## 1. Introduction

A good organisation is an organization that having the employees who work more on their tasks. Organization should maintain its quality and quantity better than its worker because the workers are essential assets of the organization. A good employee will perform a good behaviour within the organization. A good employee focuses on the work satisfaction and organizational commitment. Organizational commitment is a loyal sense of employees toward the recent organization. Organizational commitment comes from the perceived organizational supported, extrinsic and intrinsic reward in each individual. In an organization, the given reward system will motivate and preserve the competence employee as an asset (Robbins & Judge, 2015).

In the organization system, the reward system can have a good effect to increase organizational commitment. In addition, reward system can also be used to maintain and retain the assets of competent employees. According to Mahane and Lederer (2006), there are two types of rewards: intrinsic and extrinsic rewards. Besides that issues, the perceived organizational support is also needed by the organization in order to make the employee has assumption towards the organization. Thus, the employee organizational commitment will also be improved. If the organizational commitment is improved, it will be owned by each of individual. The extrinsic reward will be obtained by the organization as an appreciation form of all of the work done by those employees. The perceived organisation support is an expression for the employee towards its organization in respecting all of the contribution and compassion by the employee.

Madukismo is a factory of sugar, alcohol, and spiritus located in Special Region of Yogyakarta, Indonesia. Madukismo Sugar Factory is established in 1955 initiated by Sri Sultan Hamengkubuwono IX and certified on 29 May 1958. Madukismo Sugar Factory has some divisions : administration, financial, human resources, marketing, planting, fabrication, spiritus, public, and installation. Each division has different reward system based on the difficulty level of the division. However, the employees in Madukismo Sugar Factory felt that the reward given is not sufficient to fulfill their needs.

Intrinsic rewards are rewards within the work itself such as achievements, variations, challenges and responsibilities. Extrinsic rewards are an external reward for the work itself, which can be in form of wages, benefits, job security, promotion, private office space and social climate (Mahane and Lederer, 2006). Intrinsic rewards and extrinsic rewards are necessarily needed by employees. The intrinsic rewards must be owned by employees so that employees have the responsibility and challenge to complete the work, even extrinsic rewards must be given to employees according to the workload. In order to fulfil employees respects and attention, he

rewards given will make employees love the company where they work and employees encouraged to achieve company goals. Extrinsic rewards may also arise because of perceived organizational support by employees.

The rewards system tends to have a direct influence on direction of attention and efforts of individual employees (Bamberger and Levi, 2009). Giving a good and appropriate rewards will make the employees feel strongly appreciated and supported. The given reward will increasingly gained if employees have the perception of organizational support. The rewards can also make employees more loyal to the company. Ayesha *et al.* (2015) concluded that intrinsic rewards and extrinsic rewards have a positive effect on organizational commitment mediated by perceptions of organizational support. This study is a replication study from entitled the effects of intrinsic and extrinsic reward on employee attitudes: mediating role of perceived organizational support. The previous study was using two employee's behaviours : the work satisfaction and organizational commitment. In this study, the writer only use organizational commitment as endogenous variable.

Based on the elaboration discussed earlier, the writer interested to study the mediating role of perceived organization support on the effect of intrinsic and extrinsic rewards on organizational commitment among the employees of Madukismo sugar factory in Yogyakarta.

## 2. Hypotheses Development

### 2.1. *The effect of intrinsic reward towards perceived organizational support*

Intrinsic reward in an organization is becoming an essential factor for some of the employees because they will feel being more respected and make them increase their loyalty in the organization. Intrinsic reward in Madukismo Sugar Factory is better to be improved not only in the aspect of the confession towards the employees, but also to choose the supervisors who can solve the problem. Supervisors who wanted to hear the employee's problems and wanted to assist the problem and giving any solution. This phenomenon can be strengthened by using the previous studies that were conducted by Ayesha *et al.* (2015) and O'Driscoll (1999) who stated that intrinsic reward has a positive influence towards the perceived organizational support. If a company gives an intrinsic or extrinsic reward, indirectly it will give perceived organizational support towards the employee. This organizational perception exists because the employee feels a justice in organization, feeling respected and the employees feel the faced problem can also be solved by the organization. Then, the organization can understand about what the employee feel.

According to the explanation above, the hypothesis can be elaborated as follow :

H<sub>1</sub>: Intrinsic reward has a positive and significant effect towards perceived organizational support

### 2.2. *The effect of extrinsic reward towards perceived organizational support*

Extrinsic reward in Madukismo Sugar Factory consist of bonus, salary, promotion, etc. Extrinsic reward is given to the employees who could able to fulfill the work including the target based on the set of time, set of target, work more than the target in marketing, the employee can work more than target is given by the supervisors. The employee will get a promotion from the supervisor and being recommended to have higher position than before. Extrinsic reward will be more accepted and felt by the employee if the employee also get organization support from the current working place. Perceived organizational support becomes essential for the employee because if the employee feel the justice of their supervisor in working, the employee will feel that the supervisor is supporting and always help to solve the faced problems. It means that the employee feel being respected by the whole organization and in term it will make the employee have a high performance.

The previous study conducted by Ayesha *et al.*, (2015) and O'Driscoll (1999) stated that extrinsic rewards has a positive influence towards perceived organizational support. An offered reward has a strong influence towards the employee's performance. Extrinsic reward of the company usually given in a form of salary or fee and make the employee being respected. Extrinsic reward consists of fee, salary, bonus, and the opportunity given by the organization. Extrinsic reward will be very important with the continuing of organizational commitment owned by the employee in an organization.

According to the explanation above, the hypothesis is stated as follow :

H<sub>2</sub>: Extrinsic reward has a positive and significant effect towards perceived organizational support

### 2.3. *The effect of intrinsic reward towards organizational commitment*

The intrinsic rewards in Madukismo Sugar Factory usually in the form of recognition, justice and superiors support. Intrinsic rewards usually owned or perceived by employees who have more potential or employees who have worked long and have potential to support the company. Intrinsic rewards usually be given by the company to employees to harder and better for the future.

The study conducted by Neeru *et al.* (2007) and Gorat (2012) stated that intrinsic reward can be improved through affective commitment or normative commitment. It can be concluded that there is a significant decreasing mistake conducted by the employees if this intrinsic reward in organization. The other fact is there is a cooperation improvement within the team and organizational commitment in each individual or employee after

the application of this intrinsic reward. The employee do this because they feel that organization has given welfare to them.

According to the explanaton above, the hypothesis can be elaborated as follow :

H<sub>3</sub>: Intrinsic reward has a positive influence towards organizational commitment

#### 2.4. *The effect of extrinsic reward towards organizational commitment*

Extrinsic rewards are very important for employees who are in Madukismo Sugar Factory, employees who get extrinsic rewards which match their work, will make them more active in work and make them happy to be inside the organization at this time.

Extrinsic rewards should be given to employees who are already working in standards and are working within the time set by the organization. Extrinsic rewards are urgently needed so that employees who have helped organizational organizations realize their goals will have organizational commitment to the company. It can be seen that extrinsic rewards have a positive effect on organizational commitment. This research is supported by previous research done by Neeru *et al.* (2007) and Gorat (2012) who both mentionned that extrinsic reward can improve the employee's commitment even through affective or normative commitment. This study fund that extrinsic reward system give a big positive influence towards organizational commitment.

According to the explanation above, the hypothesis are :

H<sub>4</sub>: Extrinsic reward has a positive influence towards organizational commitment

#### 2.5. *The effect of perceived organizational support towards organizational commitment*

The employee's commitment in an organization becomes essential because the organizational commitment can also determine the success of the organization. An employee who has organizational commitment their working behaviour usually is responsible and loyal towards the organization. Employee's organizational commitment that is not unilateral. In this case, an organization and its employee working together and should create a good term and condition in order to make a good situation and condition. Organization always give an opportunity towards the employees to create an achievement, usually it will have a significant influence towards the behaviour and commitment. An employee who has a commitment towards organization will show high performance emotionally, lacking the absence level and have a low possibility to have a turnover (Eisenberger *et al.*, 2002). The employee will also demand organizational support towards them.

The other studies conducted by Caroline *et al.*, (2007) and O'Driscoll (1999) stated that there is a positive relation between the perceived organizational support towards the organizational commitment. It is explained that the perceived organizational support especially affective commitment, if the organizational perception felt by the employee is high, then the commitment will also high. It because they feel that the organization help them and the will not obtain anything if they are resign from the organization.

Based on the explanation above, the hypothesis can be elaborated as follow :

H<sub>5</sub>: Perceived organizational support has a positive and significant effect towards organizational commitment

#### 2.6. *The role of perceived organizational support on the effect of intrinsic reward towards the organizational commitment*

A study conducted by Ayesha *et al.*, (2015); Allen & Meyer (1996) and Eisenberger *et al.*, (1986) stated that a company will focus on the organizational commitment to their employee and appropriate with the employee's support perception of the current working place. It is an employee's perception where he/she has been recognized by the supervisor. By these sense and perception the employee will be satisfied and being more commitment for a company. A good perceived organizational support is showing the great relation between organizational support given by the company through intrinsic reward. Intrinsic reward that is given to the employee who have been working for a long periode and having a very good achievement and organizational commitment that is emerging on themselves. By increasing the reward, it will have an influence and can improve the organizational motivation and commitment of the employee. According to the explanation above, the hypothesis can be elaborated as follow:

H<sub>6</sub>: The perceived organizational support mediates the effect of intrinsic reward toward organizational commitment.

#### 2.7. *The mediating role of organizational perceived support on the effect of extrinsic reward toward on organizational commitment*

A study conducted by Ayesha *et al.* (2015); Allen & Meyer (1996); and Eisenberger *et al.*, (1986) stated that a company will focus on organizational commitment to their employee and appropriate with their company support perception. It is employee's perception or where the employee will feel that they are recognized by their supervisor. By this sense and perception, the employee will be satisfied and being more commitment to a

company. A good perceived organizational support is showing a great relation between the organizational support given by the company with more given extrinsic reward and also improving the individual's organizational commitment.

By improving the reward, it will have an influence and improving the employee's motivation and organizational commitment. Based on the elaboration above, the hypothesis is:

H<sub>7</sub>: Perceived organizational support mediates the effect of extrinsic reward towards organizational commitment.

### 3. Research Methodology

#### 3.1 Research Design and Unit Analysis

This study used quantitative method by developing a reliable and valid research instrument. These instruments consist of the mediating role of perceived organization support on the effects of intrinsic and extrinsic rewards on organizational commitment among the employees of Madukismo sugar factory Yogyakarta. The research unit is a permanent employee of Madukismo Sugar Factory Yogyakarta who has worked for 15 years.

#### 3.2 Scale Measurement

There are 4 variables analysed in this research which are intrinsic reward, extrinsic reward, organizational commitment and perceived organizational support measured using instrument with Likert scale 1 - 5, the scale represents answer rating from strongly disagree to strongly agree.

#### 3.3 Research Sample

Respondents were selected by using the proportional random sampling method of 230 permanent employees in Madukismo Sugar Factory Yogyakarta. Data obtained from the questionnaire distribution.

#### 3.4 Data Screening and Analysis

There are two steps in data analysis during this research: normality data and outlier data. The survey distributed 230 respondents and only returned 210. The analysis tool used in this study using Structural Equation Modelling (SEM) with analysis of AMOS version 22.0. All indicators that make up the variables are tested with goodness of fit (GOF) technique. The research variables were developed as follows:

*Reward intrinsic* defined that intrinsic reward is reward obtained by individual directly, its givenness is not depending on the presence and actions of another people, that is including the responsibility, challenge, and feedback. According to Gibson *et al.*, (1996) *reward extrinsic* defined that extrinsic reward or feedback obtained by the finished working and indirectly will be related to the working essence, and extrinsic reward consists of fee, salary, subsidy, and promotion from organization. Gibson *et al.*, (1996) defined *organizational commitment* as a power or condition belongs to the where parties are those employees, loyal or not the organization they are currently working and can be seen by how much far the employee's involvement in the organization (Mowday *et al.*, 1982). Perceived organizational support defined as a belief of all of the employees towards an organization about how much care and intense the organization towards the employee's welfare and to respect the contribution of those employees (Eisenberger *et al.*, 1986)

The indicators in this study will be measured by the validity to be used to measure whether the indicator on each variable is valid or not. According to (Hair *et al.*; 2010) the questionnaire items were measured using Confirmatory Factor Analysis (CFA) to test the relationship of construct validity and construct reliability. The test results of CFA tested on Table 1 showed that the value for loading factor in each question item is  $>0.5$  which can be concluded that all question items are valid. Meanwhile, Table 2 showed the value of Construct Reliability is  $>0.7$  and Variance Extracted is  $>0.5$  for each construction, which explains that all constructs are reliable. The CFA results conclude that all indicators can be used to measure variables and analyze research data.

The sample of this study is the whole employee in in Madukismo Sugar Factory Yogyakarta which is 210 people. The process of data collection is using proportional random sampling as a sample collecting method. After that, in data analysis is using SEM with AMOS method.

Table 1. The Validity Test Result Based on The Final Fit Model

Variable	Indicator	Loading Factor	Result
Intrinsic Reward	IR.1	0.771	Valid
	IR.2	0.604	Valid
	IR.3	0.822	Valid
	IR.4	0.814	Valid
Extrinsic Reward	ER.1	0.734	Valid
	ER.2	0.795	Valid
	ER.3	0.829	Valid
	ER.4	0.719	Valid
Perceived Organizational Support	POS.1	0.753	Valid
	POS.2	0.763	Valid
	POS.3	0.701	Valid
	POS.4	0.762	Valid
	POS.5	0.799	Valid
Organizational Commitment	OC.1	0.724	Valid
	OC.2	0.706	Valid
	OC.3	0.689	Valid
	OC.4	0.727	Valid
	OC.5	0.735	Valid
	OC.6	0.737	Valid
	OC.7	0.754	Valid
	OC.8	0.769	Valid
	OC.9	0.756	Valid

Source: Data analyzed by the writer (2018).

Table 2. The Reliability Test Result Based on the Final Fit Model

Variable	Indicator	Construct Reliability (CR $\geq$ 0.7)	Result
Intrinsic Reward	IR.1	0.771	Reliable
	IR.2	0.704	Reliable
	IR.3	0.822	Reliable
	IR.4	0.814	Reliable
Extrinsic Reward	ER.1	0.734	Reliable
	ER.2	0.795	Reliable
	ER.3	0.829	Reliable
	ER.4	0.719	Reliable
Perceived Organizational Support	POS.1	0.753	Reliable
	POS.2	0.763	Reliable
	POS.3	0.701	Reliable
	POS.4	0.762	Reliable
	POS.5	0.799	Reliable
Organizational Commitment	OC.1	0.724	Reliable
	OC.2	0.706	Reliable
	OC.3	0.689	Reliable
	OC.4	0.727	Reliable
	OC.5	0.735	Reliable
	OC.6	0.737	Reliable
	OC.7	0.754	Reliable
	OC.8	0.769	Reliable
	OC.9	0.756	Reliable

Source: Data analyzed by the writer (2018).

#### 4 Finding and Discussion

The hypothesis testing in this research is analyzed by using first order Structural Equation Modeling (SEM) with AMOS version 22.0. Figure 1 showed the the finding of Goodness of Fit testing in this study has fulfilled five

criteria of good-fit: RMSEA=0,066, AGFI=0,868, CMIN/DF=1,920, TLI=0,923, CFI=0,933 and GFI=0,868 is marginal fit, in and 1 criteria is not significant with Significance Probability=0,000. Five criteria are enough to make conclusion that the model is significant.

Hypothesis test results to test the effect of exogen variables can be seen in Figure 1 below:

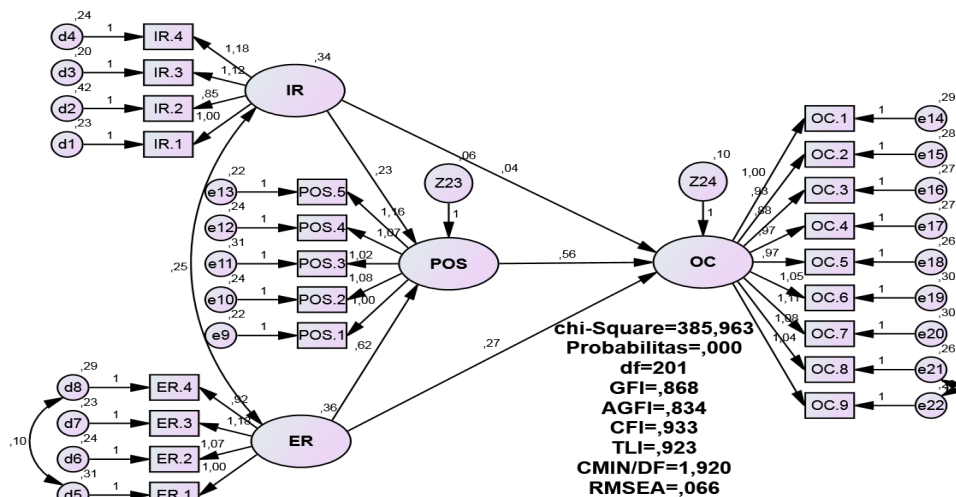

Source: Data analyzed by the writer (2018).

Figure 1. The Final Full Model Structural Equation Modelling

The path coefficient and probability value resulted from the full model of the research are shown in Tabel 3.

Table 3. The Path Coefficient and Hypotheses Testing Result

Hypotheses	Estimation	S.E.	C.R.	P	Result
POS ← IR	.235	.081	2.883	.004	Significant
POS ← ER	.623	.092	6.749	.000	Significant
OC ← IR	.038	.089	.431	.666	Not-significant
OC ← ER	.274	.144	1.969	.058	Significant
OC ← POS	.555	.176	3.158	.002	Significant

\*Significant level = 5 %

Source: Data analyzed by the writer (2018).

### Direct Effects

#### 4.1 The effect of intrinsic reward towards perceived organizational support

It is obtained that path coefficient of intrinsic reward towards the perceived organizational support is 0.235, and the C.R is 2.883 ≥ 1.96. It is concluded that intrinsic reward had positive and significant effect towards perceived organizational support. If the company increase the intrinsic reward towards the employee, consequently the employee perceived organizational support will also increase. This made the employees ill feel that the current company had fully supported to the employee.

#### 4.2 The influence of extrinsic reward towards perceived organizational support

It is obtained that path coefficient of extrinsic reward towards the perceived organizational support is 0.635, and the C.R is 6.749 ≥ 1.96. It is concluded that extrinsic reward had positive and significant effect towards perceived organizational support. If the company increase the extrinsic reward towards the employee, consequently the employee perceived organizational support will also increase. This made the employees ill feel that the current company had fully supported to the employee. Extrinsic reward has positive influence towards perceived organizational support can be defined that if a company give a suitable extrinsic reward with the employee's workload then the employee will feel that the company respect their hardworking and the company support the employee better.

#### 4.3 The effect of intrinsic reward towards organizational commitment

It is obtained that path coefficient of intrinsic reward towards the organizational commitment is 0.038, and the C.R is 0.431 ≤ 1.96. It is concluded that intrinsic reward did not have any effect towards has positive and significant effect towards organizational commitment. Intrinsic reward in Madukismo sugar factory has no effect towards the employee's commitment due to the company will give extrinsic reward (position promotion)



for their employee if they had been working for 15 years. In this position promotion will be given to the employee who have a good achievement in the company. The employee will feel that intrinsic reward takes too long time and the given intrinsic reward is not fully affecting the individual's/employee's organizational commitment.

*4.4 The effect of extrinsic reward towards organizational commitment*

It is obtained that path coefficient of extrinsic reward towards the organizational commitment is 0.275, and the C.R is  $0.431 \leq 1.969$ . It is concluded that extrinsic reward had positive and significant effect towards organizational commitment. It means that the better extrinsic reward will improve organizational commitment. Usually, the given extrinsic reward by Madukismo sugar factory to the employee that has been working based on the company target.

*4.5 The effect of perceived organizational support towards organizational commitment*

It is obtained that path coefficient of perceived organizational support towards the organizational commitment is 0.555, and the C.R is  $3.158 \geq 1.96$ . It is concluded that perceived organizational support has positive and significant effect towards organizational commitment. It means that the better perceived organizational support, then it will improve organizational commitment. It is right and can be concluded that there is a direct influence between perceived organizational support with organizational commitment. Perceived organizational support has an influence towards organizational commitment in Madukismo sugar factory has important role for the employee. Madukismo sugar factory always fully support the employee to develop their competence. The existence of employee's perceived organizational support will give an influence to organizational commitment indirectly, but the perceived organizational support is not enough because intrinsic and extrinsic reward has important role in determining the employee's organizational commitment.

**Indirect Effect**

This is the indirect effect of this study :

Table 4. Standarized Indirect Effect Testing Result

Variable	ER	IR	POS	OC
Perceived Organizational Support	.000	.000	.000	.000
Organizational Commitment	.367	.133	.000	.000

Source: Data analyzed by the writer 2018

Tabel 4 shows that it is obtained that perceived organizational support has moderating role on the effect of intrinsic and extrinsic reward toward organizational commitment. This conclusion based on the coefficient influence of intrinsic reward toward organizational commitment through perceived organizational support is 0.133 greater than direct effect only 0.038 (See Table 3). Meanwhile, perceived organizational support also has moderating role on the effect of intrinsic reward toward organizational commitment. This conclusion based on the coefficient influence of extrinsic reward toward organizational commitment through perceived organizational support is 0.367 greater than direct influence only 0.247 (See Table 3). It can be concluded that management could increase oeganizational commitment by increasing perceived organizational support through both intrinsic and extrinsic rewards.

*4.6 The mediating role of perceived organizational support in intrinsic reward towards organizational commitment*

Direct intrinsic reward value towards organizational commitment is 0,039, smaller than if it is compared to the indirect effect of 0,133. Thus, perceived organizational support is a mediating variable on the effect of the intrinsic reward towards organizational commitment. Perceived organizational support in Madukismo sugar factory is needed by the employees to make them believe that their current working place can help the employee's welfare. It makes the employee's intrinsic reward and organizational commitment being improved.

*4.7 The mediating role of perceived organizational support in intrinsic reward towards organizational commitment*

The direct extrinsic reward value towards organizational commitment is 0,291, smaller than its indirect effect of 0,367 is. Thus, perceived organizational support is mediating variable of the effect of extrinsic reward towards organizational commitment. Perceived organizational support is needed by the company in Madukismo sugar factory. By the existence of given extrinsic reward to the employee it will improve the employees' loyalty and high commitment to the company. It is better that if the given reward is added by high organizational support perception. By the existence of perceived organizational support and extrinsic reward, the employees are expected to have more organizational commitment to its current working place.

## 5. Conclusion

The grand findings of this study are : the Intrinsic reward has positive and significant effect towards the perceived organizational support, the extrinsic reward has positive and significant effects towards perceived organizational support, the Intrinsic reward has no effects towards organizational commitment, the extrinsic reward has positive and significant effects towards organizational commitment, perceived organizational support has positive and significant effect towards organizational commitment. Perceived organizational support has mediating role on the effect of intrinsic and extrinsic reward toward organizational commitment.

## 6. Suggestion

### *Managerial Implication*

In order to improve organizational commitment at Madukismo sugar factory, was recommended to the company to increase perceived organizational support. This recommendation was based on the findings that the perceived organizational support had the highest direct effect coefficient (0.55) towards organizational commitment, and it had bigger coefficient than intrinsic reward (0.038) and extrinsic reward (0.27). Because intrinsic and extrinsic reward both were also not significant in affecting the organizational commitment, so the only way to increase organizational commitment was suggested to increase intrinsic and extrinsic reward both through the perceived of organizational support.

The next recommendation is to increase perceived organizational support the company was recommended to increase both intrinsic and extrinsic rewards. Both exogenous variables, extrinsic and intrinsic were significant in affecting perceived organizational support. But the total coefficient effect of extrinsic rewards towards organizational commitment through perceived organizational support was 1.17. It was bigger than the total coefficient effect of intrinsic rewards towards organizational commitment through perceived organizational support that was only 0.78. It can be suggested managerially, that company effort to improve organizational commitment through perceived organizational support is more effective through improving extrinsic reward because it had the greater total effect.

The recommendation for the next researcher is expected to employee more variables than the current study. The alternative proposed variables are organizational culture, organization citizenship behavior, work engagement, work satisfaction and work performance.

## References

- Ayesha Ajmal; Bashir Mohsin; Abrar Muhammad; Khan Muhammad Mahroof and Saqib Shah Nawaz, (2015), "The Effect of Intrinsic and Extrinsic Reward on Employee Attitudes: Mediating Role of Perceived Organizational Support", *GC University, Faisalabad, Pakistan*.
- Allen, N. J., and Meyer, J. P. (1990), "A Three-Component Conceptualization of Organizational Commitment". *Human Resource Management Review*, 61-89
- Bamberger, P.A., & Levi, R. (2009), "Team-Based Reward Allocation Structures And The Helping Behaviors of Outcomes-Interdependent Team Members", *Journal of Managerial Psychology*.
- Caroline Aube, Vincent Rousseau, Estelle M. Morin. (2007), "Perceived Organizational Support and Organizational Commitment", *University of Montreal, Montreal, Canada*.
- Eisenberger, N., et al. (2002), "Prosocial Development in Early Adulthood: A. Longitudinal Study", *Journal of Personality and Social Psychology*, Vol. 82. No. 6. 993-1005.
- Gibson, J.L., Ivancevich, J.M. and Donnelly. (1996), "Organization, Behavior, Structure, Process". *Bina Rupa Aksara. Jakarta*
- Gorat, Ridwan. (2012), "The Influence of Reward, Supervision, Working Conditions and Partners Against Job Satisfaction and Its Impact on The Commitment of Organizational Organizations of Staff of Revenue and Financial Management of the District of TapanuliTengah", *Masters Thesis, Open University*
- Hair, Jr., J.F, et. al. (2010), "Multivariate Data Analysis, 7<sup>th</sup> edition", *Upper Saddle River; Prentice Hall*.
- Mahane, R. C. & Lederer, A.L. (2006), "The Effect of Intrinsic and Extrinsic Reward for Developers on Information System Project Success", *Project Management Journal*.
- Mowday, Richard T. *Et al.*, (1982). "Employee – Organizational Linkages: The Psychology Of Commitment Absentism And Turnover", *Academic Press Inc.*, New York.
- Neeru Malhotra, Pawan Budhwar and Peter Prowre. (2007), "Linking reward to commitment: an empirical investigation of four UK call center", *Int. J. of Human resource management* 18:12. December 2007, pp : 2095-2127.
- Robbins SP, dan Judge. (2015), "Organizational Behavior (Sixteenth Edition)", *Person Education limited, England*
- O'Driscoll, Michael P. Donna M. Randall. (1999), "Perceived Organizational Support, Satisfaction with Rewards, and Employee Job Involvement and Organizational Commitment", *University of Waikato, New Zealand*.