

# Power System Stabilizer Model Based on Fuzzy-PSO for Improving Power System Stability

Ramadoni Syahputra  
Department of Electrical Engineering,  
Faculty of Engineering,  
Universitas Muhammadiyah Yogyakarta  
Yogyakarta, Indonesia  
E-mail: [ramadoni@umy.ac.id](mailto:ramadoni@umy.ac.id)

Indah Soesanti  
Department of Electrical Engineering  
and Information Technology,  
Faculty of Engineering,  
Universitas Gadjah Mada  
Yogyakarta, Indonesia  
E-mail: [indsanti@gmail.com](mailto:indsanti@gmail.com)

**Abstract**—This paper proposed a Power System Stabilizer model based on Fuzzy-PSO for improving power system stability. Power System Stabilizer (PSS) is equipment that can be used to enhance the damping of power system during low frequency oscillations. For large scale power systems comprising of many interconnected machines, the PSS parameter tuning is a complex exercise due to the presence of several poorly damped modes of oscillation. The problem is further being complicated by continuous varied in power system operating conditions. In order to enhance the performance of PSS, the combination of fuzzy logic and particle swarm optimization (PSO) method is used in this study. Simulations were carried out using several fault tests at transmission line on a two-area multi-machine power system. As a reference the PSS model, Delta w PSS and Delta Pa PSS has been used for comparison with the PSS under considerations. The result shows that power transfer response using the PSS model is more robust than Delta w PSS and Delta Pa PSS, especially for three phase faults and phase to ground faults.

**Keywords**—Power System Stabilizer; fuzzy logic; Particle Swarm Optimization; short circuit fault; multi-machine power system.

## I. INTRODUCTION

In operation, the electrical power system is often impaired short circuit, either permanent or temporary. The short circuit can cause a deviation in the variables of the electric power system, such as voltage, frequency, and others. This deviation may affect the stability of the power system. Stability in the electric power system is defined as the ability of the power system to maintain synchronization at the time of interruption and after interruption occurs [1] – [3].

Power System Stabilizer (PSS) is a device that serves to maintain the stability of the power system. PSS action is to expand the limits of power system stability by delivering synchronous machine rotor oscillation damping via the excitation generator. Damping is provided by an electric torque applied to the rotor in line with variations of speed. On the other hand, the use of artificial intelligence-based method has a lot of help in the field of electrical power systems [4] – [10]. The use of artificial intelligence-based method is not only limited to the field of image processing [11] – [15].

In a period of four decades, various methods have been applied to design the PSS in order to improve performance of the overall system. Most of the PSS is used in the electric power system was developed based on the classical linear control theory [16]. Linear control theory refers to a linear model of the power system configuration is fixed. In other words, PSS with fixed parameters are often called conventional PSS able to function at its optimum for a particular operating condition and are not effective for the operating conditions change drastically [17]. PSS is widely used conventional power companies because simple in structure, flexibility, and easy to implement. However performance of PSS can decrease with changes in the operating conditions of electrical power systems. Because the electric power system is highly nonlinear, conventional PSS with fixed parameters could not cope with the changes to the operating conditions of electrical power systems. To overcome this there are two main approaches to stabilize the power system over a range of operating conditions, i.e. adaptive control approach and robust [18]. Adaptive control is based on the idea that it is continually renew the controlling parameter corresponding current measurement. However, adaptive control usually performance bad experience during the learning process, unless obtained really fit. Successful operation of adaptive controllers requires a reliable measurement and lasted continuously to get the desired results, if not then the control parameter settings will fail [19]. Sturdy controller will provide an effective approach despite the electrical system operating conditions vary greatly. Performance perfect on sturdy controllers will be able to overcome uncertainty obtained when control parameters. However, in order to achieve the necessary conditions and relatively high cost [20].

In this study, a Power System Stabilizer model based on Fuzzy-PSO for improving power system stability of multi-machine power system is done. Fuzzy logic is used to set the weighting in the process of optimization on the method of PSO. In this approach, it is conducted the linearized model of the machine on power system. With this approach is expected to be obtained by a relatively simple method and is suitable for power system conditions that are very varied.

## II. POWER SYSTEM STABILIZER DESIGN

### A. Fuzzy-PSO Method

Particle swarm optimization (PSO) algorithm was first published by Eberhart and Kennedy [9]. The algorithm was inspired by a flock of swarm movement in searching of food. Let us assume in n-dimensional that the position of the  $i$ -th individual is  $X_i = (x_{i1}, \dots, x_{id}, \dots, x_{in})$  and the speed of the  $i$ -th individual is  $V_i = (v_{i1}, \dots, v_{id}, \dots, v_{in})$ . The particle best  $Pbest_i = (pbest_{i1}, \dots, pbest_{id}, \dots, pbest_{in})$ . The best global position  $Gbest_i = (gbest_1, \dots, gbest_d, \dots, gbest_n)$ . The velocity of each particle is calculated as:

$$V_i^{(t+1)} = \omega \cdot V_i^{(t)} + c_1 \cdot rand_1(o) \cdot (Pbest_i - X_i^{(t)}) + c_2 \cdot rand_2(o) \cdot (Gbest_i - X_i^{(t)}) \quad (1)$$

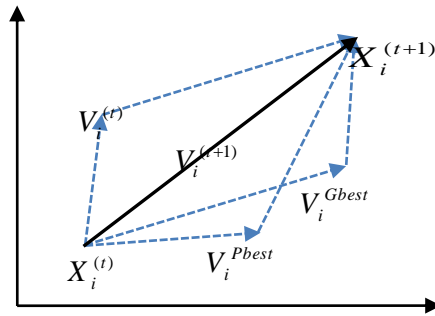

Fig. 1. The concept of optimization using PSO.

The latest position of the particle is:

$$X_i^{(t+1)} = X_i^{(t)} + V_i^{(t+1)} \quad (2)$$

where  $i = 1, 2, \dots, N$  is the index of each particle;  $t$  is the number of iterations;  $rand_1(o)$  and  $rand_2(o)$  are a random number between 0 and 1; and  $N$  is the number of the swarm.

Inertia weights  $\omega$  is:

$$\omega^{(t+1)} = \omega^{max} - \frac{\omega^{max} - \omega^{min}}{t_{max}} \times t \quad (3)$$

where  $\omega_{max}$  is the maximum inertia weight;  $\omega_{min}$  is the minimum inertia weight;  $t_{max}$  is the maximum number of iterations.

Furthermore, the PSO method is used to optimize the values of PSS fuzzy parameters, i.e. gain bands of KL, KI and KH. The gain bands is aimed to improve the performance of the PSS.

### B. Fuzzy-PSO Power System Stabilizer

Large electric power system is generally a multi-machine system connected to an infinite bus. Growing an electric power system, the more vulnerable to interference, especially interference short-circuit. One effect is the oscillation power interruption will cause the system out of the area of stability and can result in an even worse as a total blackout [1]. Based on data from Westinghouse in 1964, the probability of occurrence of short circuit for the various types of interference that is to disruption by 5% three-phase, two-phase disturbance to the land by 10%, interruption phase to phase by 15%, and the disruption of one phase to ground 70% [2].

Basically, the stability of the power system is divided into steady state stability and transient stability. Transient stability

associated with the major disruption that occurs suddenly, like a short circuit, line disconnection, removal or disconnection of the load. While the steady state stability associated with the ability of the power system to return to the conditions of its operating point after a small disturbance such as changes in power or load slowly. Steady state stability also called dynamic stability. Small changes in load will result in a change in the angular velocity of the rotor and generator terminal voltage. Angular velocity will swing around speed and voltage synchronous generator terminal converging around its nominal voltage.

In the multi-machine system, a system is said to be dynamically stable if after disturbance (load change) the difference in the angle of the rotor head at a certain finite value. If there is a difference between the generator rotor angles progressively enlarged then the system is unstable. Due to changes in the load on dynamic stability studies are relatively small, the electric power system model used in this study is a model of linear or non-linear models were linearized. Small changes in load on the power system is a matter that could not be avoided and it is always the case. Therefore, it is necessary to design a controller that can maintain the power system remains stable, commonly called Power System Stabilizer (PSS).

PSS basic function is to expand the limits of stability by modulating the generator excitation to produce oscillation damping rotor synchronous motor. The oscillation usually occurs within a frequency range of about 0.2 to 3.0 Hz, and can interfere with the ability of the system to transmit electrical power. In order to dampen these oscillations, PSS must be able to produce electric torque components according to the generator rotor speed changes. One example of the implementation of PSS in addressing the stability of the system is shown in Figure 2.

Fuzzy-PSO PSS models in this study is shown in Figure 3. In the MB-PSS applied three kinds of filters are low-pass filter, intermediate-pass filter, and high-pass filter, which serves to dampen the local oscillation, the oscillation between networks, and global oscillations [3]. By using this type of PSS, the effect on the stability of the signal due to changes in the turbine power can also be suppressed.

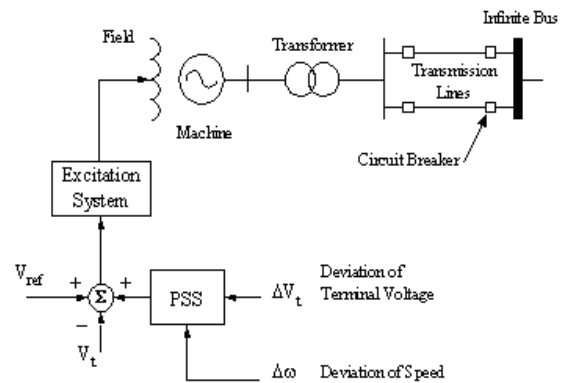

Figure 2. Implementation of PSS in generator

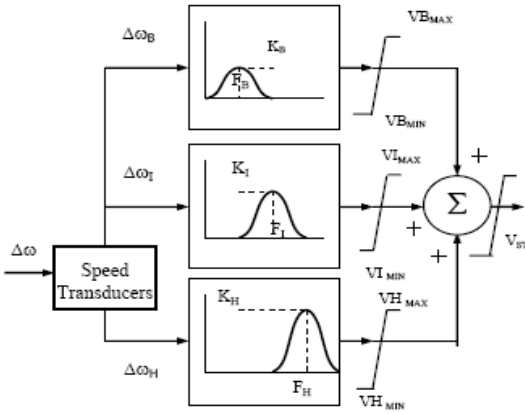

Figure 3. Diagram of Fuzzy-PSO PSS Stabilizer

The main parameters that are results of PSO optimization for setting the Fuzzy-PSO PSS are: gain band:  $K_L = 4.1$ ,  $K_I = 5.9$ ,  $K_H = 51$ , the frequency band centers:  $F_L = 0.1091$  Hz,  $F_I = 1.2001$  Hz,  $F_H = 12$  Hz. Fuzzy-PSO PSS was designed to quell disturbances that occurred in the electric power system. Disturbances caused oscillations in the electromechanical generator in the power system. Electromechanical oscillations can be classified:

1). Local Oscillation. These oscillations are caused by disorders that occur between one generator unit is active and

the inactive generator in a power station. The oscillation frequency generally ranges in the range between 0.8 to 4.0 Hz.

2). Oscillation between stations. This oscillation is caused by interference between two adjacent power stations. The oscillation frequency generally ranges in the range between 1 Hz to 2 Hz.

3). Oscillations between areas. This oscillation is caused by a disturbance between two groups of generation stations in a power system. The oscillation frequency generally ranges in the range between 0.2 to 0.8 Hz.

4). Global Oscillation. This oscillation is characterized by oscillations in the same phase in the entire generator. Global oscillation frequency is generally below 0.2 Hz. This oscillation also called power swing, and effectively should be suppressed to maintain the stability of the power system.

The Fuzzy-PSO-based PSS models applied in Matlab Simulink software as shown in Figure 4. There are three areas of the frequency used, each of which is used to handle low frequency oscillation mode low, medium, and high. Field of low frequency (low band) is generally associated with global fashion power system. Field intermediate frequency associated with the mode of inter-area power system. Medium field of high frequency is associated with a local mode (in a generating station).v

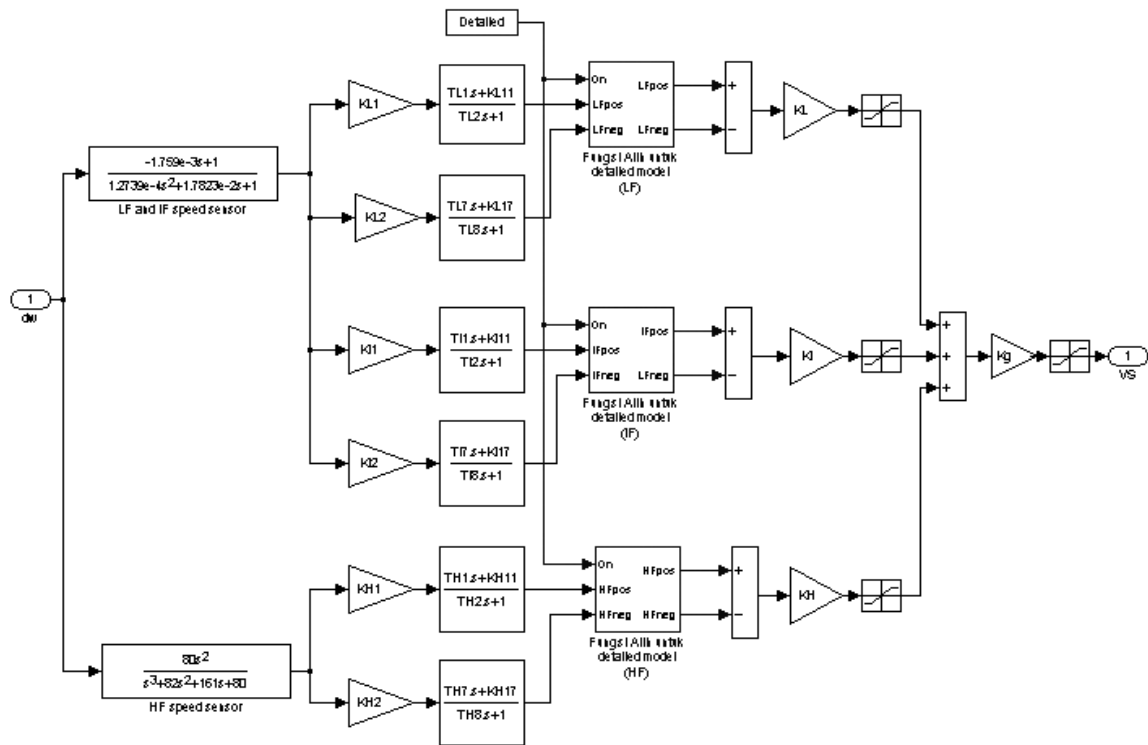

Figure 4. PSS model based on Fuzzy-PSO

### III. METHODOLOGY

This research is a model development and testing PSS models are the model of the power system circuit multi-

machine. PSS and simulation models developed in the device-software Matlab-Simulink. Research steps are summarized in the flow chart as seemingly in Figure 5.

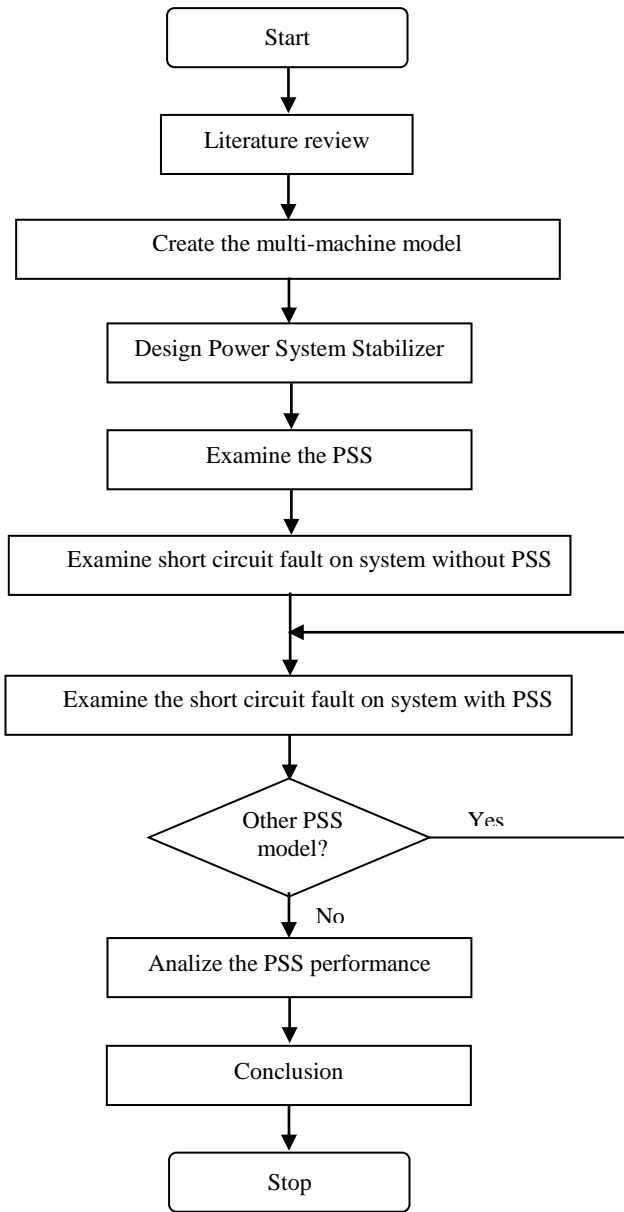

Figure 5. Research steps of this research

IV. RESULTS AND DISCUSSION

A. Power System Modeling Multi-machine

Multi-machine electric power system model used is the electric power system consisting of two areas the number generator is 4 units and the number of the bus is 10 pieces, as shown in Figure 5. Multi-machine system consists of two areas that are connected by a 220 km transmission lines. The nominal voltage is the system used is 230 kV. Each area has two synchronous generators with the same capacity is 900MVA at a voltage of 20 kV. Each generator in both areas (M1, M2, M3, and M4) is connected to the power transformers (T1, T2, T3, and T4). Fourth generators have identical parameters, except inertia (H) is for generators in area 1 of 6.5 seconds and to a generator in area 2 by 6.175 seconds.

Each generator is capable of producing active power of 700

MW. Generator load is assumed to be a big burden with constant impedance. Load in area 1 of 967 MW (L1) and in area 2 of 1767 MW (L2). In this condition shows that the area 1 has excess power, while the second area opposite of power shortage, therefore, as shown in Figure 6 there is a 413 MW power is transferred from one area to area 2. In order to improve the voltage profile in each area then installed two power capacitors (C1 and C2) each with a capacity of 187 MVAR to improve the power factor.

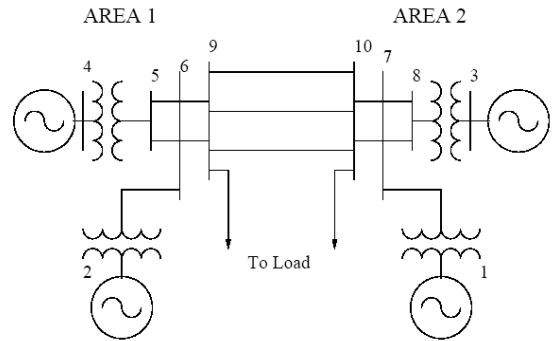

Figure 6. Multi-machine system of IEEE standard for 4 generator 10 bus by interference on the transmission line

Electric power system circuit diagram multi-machine in Figure 6 is based on the data above is implemented in software Matlab-Simulink for simulation of power system experiencing interference on the transmission line.

B. PSS Performance on Small-Signal

In order to test the signal-small performance in the form of 12-cycle pulse on the reference voltage M1, then the simulation response closed-loop systems is created. To simulate the closed-loop system response signal (small-signal), CB transition time and tool interference on the main diagram should be disabled by multiplying by 100. Then the timer block M1 controller reference voltage switched by changing the multiplier factor of 100 to 1. Choose PSS types to perform simulations with PSS models determine the choice of 1, 2, or 3. Furthermore, simulation and recorded some of the variables that will be used as a comparative study between types of PSS. Important variables eg engine rotation speed and terminal voltage stored in the matrix W and the matrix Vt, which can be seen in the block "Machine" and block "system" in the main diagram. The same process is done for all three types of PSS to be tested. To see the comparison performance each PSS, then double-click the icon "Show Results: Step Vref M1". In the images shown, there are four plots that first plot shows the power transfer from area 1 to area 2, the second plot shows the M1 engine rotation speed, a third plot shows the acceleration power M1 machines, and the fourth plot (bottom) shows the terminal voltage M1 machine.

Based on Figure 7 is shown that the entire PSS can work well in order to stabilize the system which is basically unstable system. From the Figure is also seen that in general the Fuzzy-PSO PSS results of this research have performance relatively better than Delta w PSS and Delta Pa PSS. Fuzzy-

PSO PSS were significantly able to reduce the oscillation system.

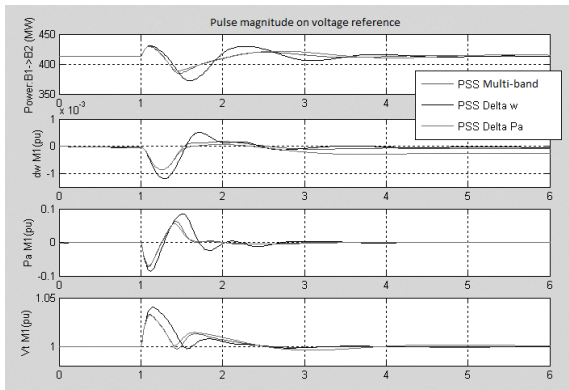

Figure 7. Performances of each PSS.

C. PSS Performance on Three Phase Symmetrical Fault

To test performance a PSS in addressing issues of dynamic stability of electric power systems especially multi-machine system, then tested the system with a large signal which is usually caused by changes in the operating conditions of the system. Based on Figure 8 shows that the performance system using Delta Pa PSS very bad. It is seen that the system failed to synchronize. Synchronization failure is due to the Delta Pa PSS using an open loop system is unable to improve response poor results. While using the Fuzzy-PSO PSS and also Delta w PSS succeeded in maintaining the stability of the power system multi-machine.

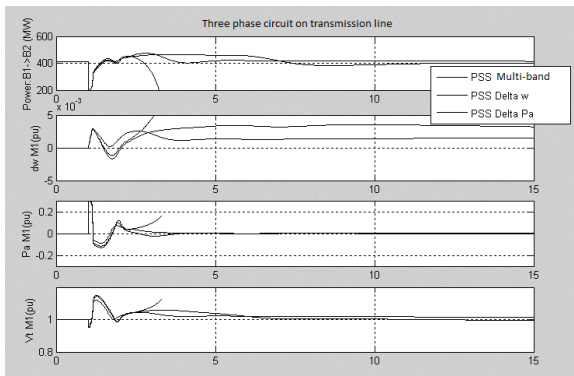

Figure 8. Performance of PSS in three-phase symmetrical fault on the transmission line

As seen in the picture that both Delta w PSS and Delta Pa PSS is very effective in dampening oscillations power transfer. But in terms of the frequency of the closed loop swing, designed by PSS lower than other types, namely time to reach a normal terminal voltage relatively shorter. While Delta w PSS requires a very long time to reach the terminal voltage conditions. Moreover also in terms of acceleration power, the PSS can reduce design results more quickly than other types PSS. This is due to the design used in PSS filter LF, MF, and HF.

D. Performance of PSS on Phase to Ground Fault

Furthermore, the simulation phase to ground disturbance on the transmission line to a state without and with PSS. The goal is to find out more about PSS performance against engine characteristics M1, M2, M3, and M4 on the system multi-machine simulated. The results of the three-phase symmetrical interference test to see performance machine is shown in Figure 9.

In Figure 9 shows that the Fuzzy-PSO PSS using fast sampling method gives very good results, which is marked by the achievement of stability multi-machine system. It appears that the bus voltage bus B1 and B2 practical experience stability in the second-to-4 after previously having state phase transition due to soil disturbance on the transmission line. Almost the same situation also occurred in the graph of the power transfer area 1 to area 2 as shown in Figure 9. It appears that despite a overshoot at the second-to undershoot the 0.5 and 1.2 seconds due to the short circuit phase to ground then the stability of the power system is experiencing the second-to-4. This state is a state that is expected to improve system performance.

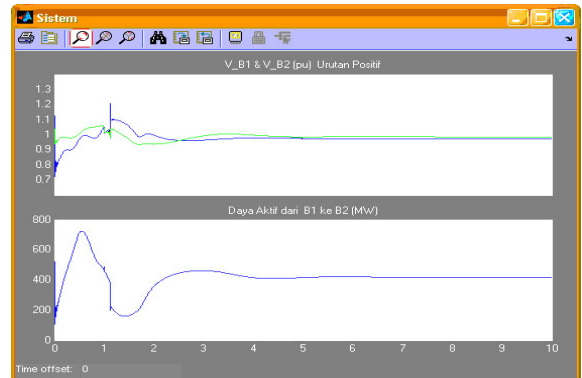

Figure 9. Voltage profile voltage and active power flow interruption during the phase to ground fault

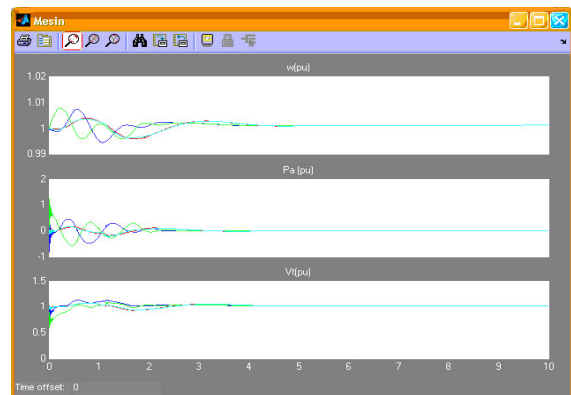

Figure 10. Engine rotation angular velocity (w), changes in engine power (Pa), and the terminal voltage (Vt) condition during phase to ground fault

PSS excellence designed by using the sampling method quickly to address the problem of transient stability of the system is also shown in Figure 10. It appears that for variable speed engine rotation angle (w), changes in engine power (Pa),

and the terminal voltage (Vt) also experienced stability which is very significant in the second-to-third, despite a oscillation until the second-to-1.5 phase to ground due to interference on the transmission line.

## V. CONCLUSION

Based on the PSS application testing on the machine M1 of the power system multi-machine to short circuit symmetrical three-phase PSS found that good design results in this study. Delta w PSS and Delta Pa PSS gives relatively good results in reducing oscillation system variables of which transfer electrical power, changes in angular velocity generator, and the generator terminal voltage. However, Fuzzy-PSO PSS results in this study have the performance relatively better than Delta w PSS and Delta Pa PSS in terms of ability to reduce oscillation and speed of reaching a state of instability. Based on testing PSS, it can be seen the characteristics of all four engines in the power system model multi-machine. The results showed that Fuzzy-PSO PSS using feedback method of sampling rapidly deliver good results compared Delta w PSS and Delta Pa PSS primarily on the state of the system is experiencing a phase short circuit to ground and phase to phase disturbances on the transmission line. In both fault type, Fuzzy-PSO PSS is able to make the state of the system became stable after four seconds later to various variables of which the voltage on the bus of multi-machine system, transfer power from area 1 to area 2, the speed of the generator rotor angle, change the power generator, and the terminal voltage of the generator.

## VI. ACKNOWLEDGMENT

The author gratefully acknowledges the contributions of the Directorate General of Higher Education (DIKTI), Ministry of Research, Technology and High Education, Republic of Indonesia, for funding this research.

## REFERENCES

- [1] Saadat, H. (1999). Power System Analysis, Singapore, McGraw-Hill, 1999.
- [2] R. Syahputra, Distributed Generation: State of the Arts dalam Penyediaan Energi Listrik. LP3M UMY, Yogyakarta, 2012.
- [3] Agus Jamal, Ramadoni Syahputra, "UPFC Based on Adaptive Neuro-Fuzzy for Power Flow Control of Multimachine Power Systems", International Journal of Engineering Science Invention (IJESI), Vol. 2, No. 10, pp. 5-14, 2013.
- [4] R. Syahputra, I. Robandi, and M. Ashari, Reconfiguration of Distribution Network with DG Using Fuzzy Multi-objective Method, Int. Conference on Innovation, Management and Technology Research (ICIMTR), May 21-22, 2012, Melacca, Malaysia.
- [5] R. Syahputra, I. Robandi, and M. Ashari, Distribution Network Efficiency Improvement Based on Fuzzy Multi-objective Method. IPTEK Journal of Proceedings Series. 2014; 1(1): 224-229.
- [6] R. Syahputra, "Fuzzy Multi-Objective Approach for the Improvement of Distribution Network Efficiency by Considering DG", IJCSIT, Vol. 4, No. 2, pp. 57-68, April 2012.
- [7] R. Syahputra, I. Robandi, and M. Ashari, Optimization of Distribution Network Configuration with Integration of Distributed Energy Resources Using Extended Fuzzy Multi-objective Method, International Review of Electrical Engineering (IREE), vol.9, no.3, 2014.
- [8] R. Syahputra, I. Robandi, and M. Ashari, "Optimal Distribution Network Reconfiguration with Penetration of Distributed Energy Resources", in Proceeding of ICITACEE 2014, Semarang, Indonesia, 2014.
- [9] R. Syahputra, I. Robandi, and M. Ashari, "Performance Improvement of Radial Distribution Network with Distributed Generation Integration Using Extended Particle Swarm Optimization Algorithm", International Review of Electrical Engineering (IREE), vol.10, no.2, 2015. pp.293-304.
- [10] R. Syahputra, I. Robandi, and M. Ashari, "PSO Based Multi-objective Optimization for Reconfiguration of Radial Distribution Network", International Journal of Applied Engineering Research (IJAE), vol.10, no.6, 2015. pp. 14573-14586.
- [11] H.A. Nugroho, N. Faisal, Indah Soesanti, L. Chorida, Identification of malignant masses on digital mammogram images based on texture feature and correlation based feature selection, International Conference on Information Technology and Electrical Engineering (ICITEE), Yogyakarta, 2014.
- [12] R.N. Rohmah, A. Susanto, Indah Soesanti, M. Tjokronagoro, Computer Aided Diagnosis for lung tuberculosis identification based on thoracic X-ray, International Conference on Information Technology and Electrical Engineering (ICITEE), Yogyakarta, 2013.
- [13] H. Afrisal, M. Faris, P. Utomo, Indah Soesanti, F. Andri, Portable smart sorting and grading machine for fruits using computer vision, International Conference on Computer, Control, Informatics and Its Applications, IC3INA 2013.
- [14] H.A. Nugroho, N. Faisal, I. Soesanti, L. Chorida. "Analysis of digital mammograms for detection of breast cancer". Proceeding - 2014 International Conference on Computer, Control, Informatics and Its Applications: "New Challenges and Opportunities in Big Data", IC3INA 2014.
- [15] R.N. Rohmah, A. Susanto, I. Soesanti. "Lung tuberculosis identification based on statistical feature of thoracic X-ray". 2013 International Conference on Quality in Research, QiR 2013 - In Conjunction with ICCS 2013: The 2nd International Conference on Civic Space.
- [16] Jyothsna, T.R., & Vaisakh, K. Multi-objective Evolutionary Programming Based Design of PSS, SVC, and TCSC for Transient Stability Improvement, Proceedings of World Academy of Science: Engineering & Technology; 39, 859-863. 2009.
- [17] Lerm, A.A.P., & Silva, A.S.E. PSS tuning via Hopf Bifurcation sensitivity analysis, IEEE Bologna Power Tech Conference, Bologna, Italy, 2003.
- [18] Robandi, I. & Kharisma, B. Design of Interval Type-2 Fuzzy Logic Based Power System Stabilizer. Proceedings of World Academy of Science, Engineering and Technology, 1, 682-689, 2008.
- [19] R. Syahputra, I. Robandi, and M. Ashari, "Performance Analysis of Wind Turbine as a Distributed Generation Unit in Distribution System", International Journal of Computer Science & Information Technology (IJCSIT) Vol 6, No 3, pp. 39-56, June 2014.
- [20] R. Syahputra, I. Robandi, M. Ashari, Modeling and Simulation of Wind Energy Conversion System in Distributed Generation Units, 3rd International Seminar on Applied Technology, Science and Arts (APTECS), 2011, pp. 290-296.