

Power Flow Control of Power Systems Using UPFC Based on Adaptive Neuro Fuzzy

by Agus Jamal

Submission date: 14-Sep-2019 11:19AM (UTC+0700)

Submission ID: 1172464951

File name: B8_Agus_Jamal.pdf (398.29K)

Word count: 3458

Character count: 17841

Power Flow Control of Power Systems Using UPFC Based on Adaptive Neuro Fuzzy

Agus Jamal¹ and Ramadoni Syahputra¹

Abstract—Optimization of system capacity electric power transmission systems requires a reliable power flow controller. The power flow controllers must be able to control the level of electrical voltage and active and reactive power flow without reducing the level of stability and security of the transmission system. Latest technology in the control of power flow is a Unified Power Flow Controller (UPFC). The entire transmission line parameters are impedance, voltage, and phase angle can be controlled simultaneously by the UPFC. The method used in the conventional algorithms based UPFC is still firmly with logic. These algorithms have difficulties to electric power transmission systems multimachine very dynamic, i.e. systems that are experiencing rapid changes in the electrical load from time to time. Therefore, in this study was developed based on neuro-fuzzy method is applied to the adaptive UPFC for adaptively controlling the power flow in electric power transmission systems multimachine very dynamic. In this study, three phase fault is applied to the multimachine system. The results are taken to be consideration of PI and neuro-fuzzy controllers. The PI and neuro-fuzzy controllers show nearly same results but there is a low overshoot occurred during the fault in the neuro-fuzzy controllers results. According to results that UPFC improves the system performance under the transient and the normal conditions. However, it can control the power flow in the transmission line, effectively.

Keywords—Power flow, UPFC, fuzzy logic controller, neural networks, adaptive controller.

I. INTRODUCTION

Electrical power systems in modern era are characterized by extensive system interconnections and increasing dependence on control for optimum utilization of existing resources. The supply of reliable and economic electric energy is a major determinant of industrial progress and consequent rise in the standard of living [1]. The growth of the power systems in the future will rely on increasing the capability of existing power transmission systems rather than building the new transmission lines and the power stations for an economical and an environmental reasons. The requirement of the new power flow controllers, which is capable of increasing the transmission reliability and controlling the power flow through the predefined corridors, will certainly increase due to the deregulation of the electricity markets. Additionally, the new controllers must be regulate the voltage levels and the flow of the real and reactive power in the transmission line to use full capability of the system in some cases with no reduction in the system stability and security margins [2]. Flexible Alternating Current Transmission Systems (FACTS) is an evolving technology based solution to help electric utilities fully utilize their transmission assets. The technology was presented in the late of 1980s [3]. FACTS devices enhance the stability of the power system with its fast control characteristics and continuous compensating capability [4].

Unified Power Flow Controller (UPFC) is the member of FACTS device that has emerged for the controlling and the optimization of power flow in the electrical power transmission systems [5]. This device formed of the combination of two other FACTS devices namely as Static Synchronous Compensator (STATCOM) and the Static Synchronous Series Compensator (SSSC). These

are connected to each other by a common DC link, which is a typical storage capacitor [6]. The all parameters of the power transmission line (impedance, voltage and phase angle) can be control simultaneously by UPFC.

In the literature, several control mechanisms are used in UPFC models. A fuzzy inference system described in matrix form is proposed and used to improve the dynamic control of real and reactive power [7]. Two fuzzy logic controllers based on Mamdani type fuzzy logic are used. One of the controllers is proportional fuzzy logic controller (PF-UPFC) and the other is Hybrid fuzzy logic UPFC (HF-UPFC). The selection of suitable location for UPFC is studied and composite-criteria based fuzzy logic is used to evaluate the network contingency ranking. The power-feedback control scheme is used in the control mechanism of UPFC [8]. The power fluctuation is damped readily and the value of reactive power is minimized as possible by using several time constants. However there is no value changed in the real power. The control method of variable interval-fuzzy-mutual is used in the control mechanism of UPFC [9]. In the simulation results, there is a high overshoot values occurred both real power and bus voltage during the three phase faults applied. However, the real power value is increased but there is no value changed in the reactive power. The performance of UPFC is observed by using three different controllers [10].

The capability of UPFC on controlling of the power flow and the effectiveness of controllers on performance of UPFC in the power transmission line are examined by using different control mechanisms based on PI and neuro-fuzzy controllers in this research. In the modeling of fuzzy controller, Takagi-Sugeno Inference System is used in the decision making process and “Weighted Average” method which is the special case of “Mamdani” model is used in the defuzzification process. The Matlab-Simulink software is used to create UPFC model and to obtain the results of case studies.

¹Agus Jamal and Ramadoni Syahputra are with Departement of Electrical Engineering, Universitas Muhammadiyah Yogyakarta, Yogyakarta, Indonesia. E-mail: ajamal_te@yahoo.com; ramadons@ymail.com.

II. FUNDAMENTAL THEORY

A. The UPFC System

A Unified Power Flow Controller (UPFC) consists of 2 forced-commutated voltage source converters (VSC) connected through a common DC link [11]. One converter is shunt-connected and the other is connected in series with the transmission line, as illustrated in Figure 1. The name "unified power flow controller" comes from the fact that it is possible for the device to control both transmitted active and reactive power as well as the AC bus voltage at the point where the shunt converter is connected (i.e., point A). The UPFC can provide different functions when the inserted series voltages v_s have different magnitudes and phase angles. It will function as a pure voltage regulator if the inserted series voltage is in phase with the AC bus voltage. It is also possible for the UPFC to function as a phase angle regulator. Each UPFC converter can independently generate or absorb reactive power. This arrangement enables the free flow of active power in either direction between the AC terminals of the 2 converters.

In the case of the parallel branch of the UPFC, the active power exchanged with the system primarily depends on the phase shift of the converter output voltage with respect to the system voltage, and the reactive power is controlled by varying the amplitude of the converter output voltage. However, the series branch of the UPFC controls active and reactive power flows in the transmission line by the amplitude and phase angle of the series injected voltage. Therefore, the active power controller can significantly affect the level of reactive power flow and vice versa. To improve the performance of the UPFC, the interaction between the active and reactive power flow control system must be reduced. In recent years, a number of investigations have been carried out to demonstrate the capabilities of UPFC as an effective power flow control [4], providing voltage control [5], transient stability enhancement [6], and oscillation damping [7-9]. It has been reported in the literature that a strong dynamic interaction exists between the active and reactive power flows through a transmission line when they are controlled by series injected voltage v_s of the UPFC. Furthermore, the UPFC is highly nonlinear because it consists of converters, power transformers, filters, and surge arrestors. Uncertainties in the power system make it difficult to model the transmission system accurately.

B. ANFIS Method

Adaptive neuro-fuzzy approach has become a popular method in control area in the last two decades. In this section, a brief description of the adaptive neuro-fuzzy inference system (ANFIS) principles given which are referred to [12-13]. The fundamental structure of the type of fuzzy inference system (FIS) could be seen as a model that maps input characteristics to input

membership functions. Then it maps input membership function to rules and rules to a set of output characteristics. Finally it maps output characteristics to output membership functions, and the output membership function to a single valued output or a decision associated with the output. It has been considered only fixed membership functions that were chosen arbitrarily. Fuzzy inference system (FIS) is only applied to only modeling systems whose rule structure is essentially predetermined by the user's interpretation of the characteristics of the variables in the model. However, in some modeling situations, it cannot be distinguish what the membership functions should look like simply from looking at data. Rather than choosing the parameters associated with a given membership function arbitrarily, these parameters could be chosen so as to tailor the membership functions to the input/output data in order to account for these types of variations in the data values. In such case the necessity of the adaptive fuzzy inference system becomes obvious.

Neuro-adaptive learning techniques provide a method for the fuzzy modeling procedure to learn information about a data set. It computes the membership function parameters that best allow the associated fuzzy inference system to track the given input and output data. A network-type structure similar to that of an artificial neural network can be used to interpret the input and output map so it maps inputs through input membership functions and associated parameters, and then through output membership functions and associated parameters to outputs. The parameters associated with the membership functions changes through the learning process. The computation of these parameters (or their adjustment) is facilitated by a gradient vector. This gradient vector provides a measure of how well the fuzzy inference system is modeling the input/output data for a given set of parameters. When the gradient vector is obtained, any of several optimization routines can be applied in order to adjust the parameters to reduce some error measure. This error measure is usually defined by the sum of the squared difference between actual and desired outputs. ANFIS uses a combination of back propagation procedure and least squares estimation for membership function parameter estimation.

Figure 2 shows Sugeno's fuzzy logic model. Figure 3 shows the architecture of the ANFIS, comprising by input, fuzzification, inference and defuzzification layers. The network can be visualized as consisting of inputs, with N neurons in the input layer and F input membership functions for each input, with F*N neurons in the fuzzification layer. There are FN rules with FN neurons in the inference and defuzzification layers and one neuron in the output layer. For simplicity, it is assumed that the fuzzy inference system under consideration has two inputs x and y and one output z as shown in Figure 3. For a zero-order Sugeno fuzzy model, a common rule set with two fuzzy if-then rules is the following:

$$\text{Rule 1: If } x \text{ is } A_1 \text{ and } y \text{ is } B_1, \text{ Then } f_1 = r_1 \quad (1)$$

$$\text{Rule 2: If } x \text{ is } A_2 \text{ and } y \text{ is } B_2, \text{ Then } f_2 = r_2 \quad (2)$$

Here the output of the i -th node in layer n is denoted as $O_{n,i}$:

Layer 1. Every node i in this layer is a square node with a node function:

$$O_i^1 = \mu_{Ai}(x), \text{ for } i = 1, 2, \quad (3)$$

or,

$$O_i^1 = \mu_{Bi-2}(y), \text{ for } i = 3, 4 \quad (4)$$

where x is the input to node- i , and A_i is the linguistic label (small, large, etc.) associated with this node function. In other words, O_i^1 is the membership function of A_i and it specifies the degree to which the given x satisfies the quantifier A_i . Usually $\mu_{Ai}(x)$ is chosen to be bell-shaped with maximum equal to 1 and minimum equal to 0, such as the generalized bell function:

$$\mu_{Ai}(x) = \frac{1}{1 + \left[\frac{x - c_i}{a_i} \right]^{2b_i}} \quad (5)$$

Parameters in this layer are referred to as premise parameters.

Layer 2. Every node in this layer is a circle node labeled Π which multiplies the incoming signals and sends the product out. For instance,

$$O_i^2 = w_i = \mu_{Ai}(x) \times \mu_{Bi}(y), \quad i = 1, 2. \quad (6)$$

Each node output represents the firing strength of a rule.

Layer 3. Every node i in this layer is a circle node labeled N . The i -th node calculates the ratio of the i -th rule's firing strength to the sum of all rules firing strengths:

$$O_i^3 = \bar{w}_i = \frac{w_i}{w_1 + w_2}, \quad i = 1, 2. \quad (7)$$

For convenience, outputs of this layer will be called normalized firing strengths.

Layer 4. Every node i in this layer is a square node with a node function:

$$O_i^4 = \bar{w}_i f_i = \bar{w}_i (p_i x + q_i y + r_i) \quad (8)$$

where w_i is the output of layer 3, and $\{p_i, q_i, r_i\}$ is the parameter set. Parameters in this layer will be referred to as consequent parameters.

Layer 5. The single node in this layer is a circle node labeled Σ that computes the overall output as the summation of all incoming signals, i.e.,

$$O_i^5 = \sum \bar{w}_i f_i \quad (9)$$

III. METHODOLOGY

The procedure of this research is shown in Fig. 4. The simulation environment based on Matlab software is selected. It is used as the main engineering tool for performing modeling and simulation of multi-machine power systems, as well as for interfacing the user and appropriate simulation programs. Matlab has been chosen due to availability of the powerful set of

programming tools, signal processing, numerical functions, and convenient user-friendly interface. In this specially developed simulation environment, the evaluation procedures can be easily performed. We have used Fuzzy logic Toolbox of Matlab to develop the ANFIS model with 4 inputs and single output.

IV. SIMULATION RESULTS

In this study, we have made a model of a multi-machine power system in Matlab-Simulink software. A UPFC is used to control the power flow in a 500 kV/230 kV transmission system, as shown in Figure 5. The system, connected in a loop configuration, consists essentially of five buses (B1 to B5) interconnected through three power transmission lines (L1, L2, L3) and two 500 kV/230 kV power transformer banks Tr1 and Tr2. Two power plants located on the 230 kV system generate a total of 1500 MW which is transmitted to a 500 kV transmission line, 15000 MVA equivalent and to a 200 MW load connected at bus B3. Each plant model includes a speed regulator, an excitation system as well as a power system stabilizer (PSS). In normal operation, most of the 1200 MW generation capacity of power plant #2 is exported to 500 kV transmission system equivalent through two 400 MVA power transformers connected between buses B4 and B5. For this demo we are considering a contingency case where only two power transformers out of three are available ($Tr2 = 2 \times 400 \text{ MVA} = 800 \text{ MVA}$). The load flow shows that most of the power generated by plant #2 is transmitted through the 800 MVA transformer bank (899 MW out of 1000 MW) and that 96 MW is circulating in the loop. Transformer Tr2 is therefore overloaded by 99 MVA. The example illustrates how a UPFC can relieve this power congestion. The UPFC located at the right end of line L2 is used to control the active and reactive powers at the 500 kV bus B3, as well as the voltage at bus B UPFC. The UPFC consists of two 100 MVA converters.

Three phase fault is applied to the multimachine system. The series converter is rated 100 MVA with a maximum voltage injection of 0.1 pu. The shunt converter is also rated 100 MVA. Also, the shunt converter is in Voltage regulation mode and that the series converter is in Power flow control mode. Dynamic responses of the UPFC are shown in Figure 6. The UPFC reference active and reactive powers are shown in the magenta blocks labeled Pref(pu) and Qref(pu). Initially the Bypass breaker is closed and the resulting natural power flow at bus B3 is 587 MW and -27 Mvar. The Pref block is programmed with an initial active power of 5.87 pu corresponding to the natural power flow. Then, at $t=10s$, Pref is increased by 1 pu (100 MW), from 5.87 pu to 6.87 pu, while Qref is kept constant at -0.27 pu.

Further results are shown in Figure 6. The figure shows the UPFC dynamic response to changes in load of power system from 587 MW to 687 MW. Figure 7 shows the controllability region of UPFC. In Figure 7 are shown the results of UPFC control for active power through bus B3 and B4 with tap position changes of PST. Based on Figure 7, it can be seen that the neuro-fuzzy UPFC is able to provide a response that controls the flow of electrical power is good.

V. CONCLUSION

In this study, neuro-fuzzy based method is applied to the UPFC for adaptively controlling the power flow in electric power transmission systems multimachine very dynamic. Three phase fault is applied to the multimachine system. The results are taken to be consideration of neuro-fuzzy controller. The neuro-fuzzy controller show low overshoot occurred during the fault in results. According to results that UPFC improves the system performance under the transient and the normal conditions. However, it can control the power flow in the transmission line, effectively.

ACKNOWLEDGEMENT

The author is gratefully acknowledge the contributions of the Directorate General of Higher Education (DIKTI), Ministry of Education and Culture, Republic of Indonesia, for funding in this research under Competitive Research Grant (Program Penelitian Hibah Bersaing), Number of Contract: 1142.19/K5/KL/2013.

REFERENCES

[1]. K.R. Padyar, "Power System Dynamics, Stability and Control", John Wiley and Sons, 1996.
 [2]. L. Saribulut, M. Tumay, and I. Eker, "Performance Analysis of Fuzzy Logic Based Unified Power Flow Controller", World Academy of Science, Engineering and Technology, 45, 2008, 30-325.
 [3]. Y. H. Song, A. T. Jons, "Flexible AC Transmission Systems (FACTS)", IEE Power and Energy Series, 30, 1999.

[4]. B. Lu, L. Hou, B. Li, Y. Liu, "A New Unified Power Flow Fuzzy Control Method", Innovative Computing, Information and Control, Second International Conference, 2007, 239-479.
 [5]. A.T. Al-Awami, Abdel-Magid, Y.T., dan Abido, M.A., "A particle-swarm-based approach of power system stability enhancement with unified power flow controller", International Journal of Electrical Power & Energy Systems, 29, 2007, pp.251-259, 2007.
 [6]. S. Kannan, S. Jayaram, M. M. A. Salama, "Real and Reactive Power Coordination for a Unified Power Flow Controller", IEEE Transactions on Power Systems, 19(3), 2004, 1454-1461.
 [7]. A.A. Eldamaty, Faried, S.O., Aboreshaid, S., "Damping Power System Oscillations Using A Fuzzy Logic Based Unified Power Flow Controller", IEEE Conference of ICEE/CCGEI, May 2005.
 [8]. T. Allaoui, Denar, M.A., dan Bouhamida, M., "Robust control of unified power flow controller (UPFC)", Journal of Electrical and Electronics Engineering (IU-JEEE), 7, 2007, 331-343.
 [9]. J. Guo, Crow, M.L. dan Sarangapani, J., "An improved UPFC control for oscillation damping", IEEE Transactions on Power Systems, 14, 2009, 288-296.
 [10]. S. Hameed, Das, B., dan Pant, V., "A self-tuning fuzzy PI controller for TCSC to improve power system stability", Electric Power Systems Research, 78, 2008, 1726-1735.
 [11]. S. Morsli, Tayeb, A., Mouloud, D., Abdelkader, C., "A robust adaptive fuzzy control of a unified power flow controller", Turkey Journal of Elec. Eng. & Comp. Science, 20(1), 2012.
 [12]. T. Takagi, M. Sugeno, "Fuzzy Identification of Systems and Its Applications to Modeling and Control". IEEE Transaction on Systems, Man and Sybem, 1985, 1: 116-132.
 [13]. Jang, J.S.R., "ANFIS: Adaptive-Network-based Fuzzy Inference System", IEEE Trans. Syst., Man, Cybern., 23, 1993, 665-685.

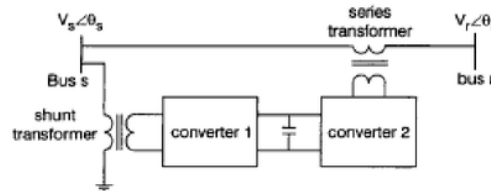

Figure 1. Basic circuit of a UPFC in transmission line

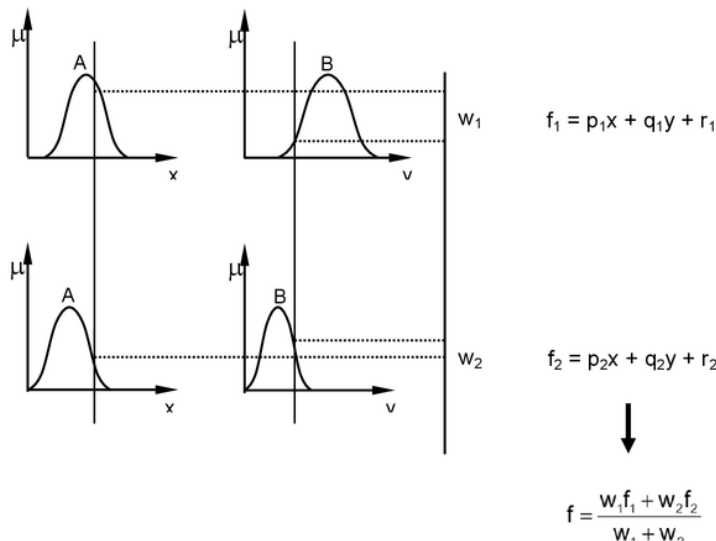

Figure 2. Sugeno's fuzzy logic model

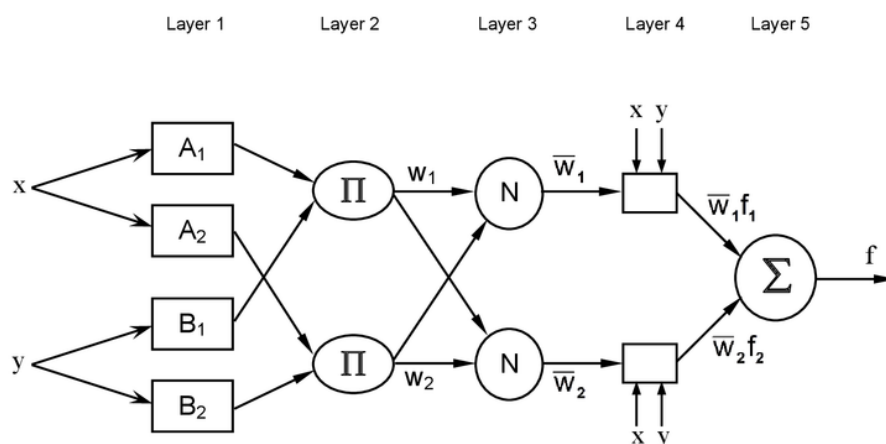

Figure 3. The architecture of the ANFIS

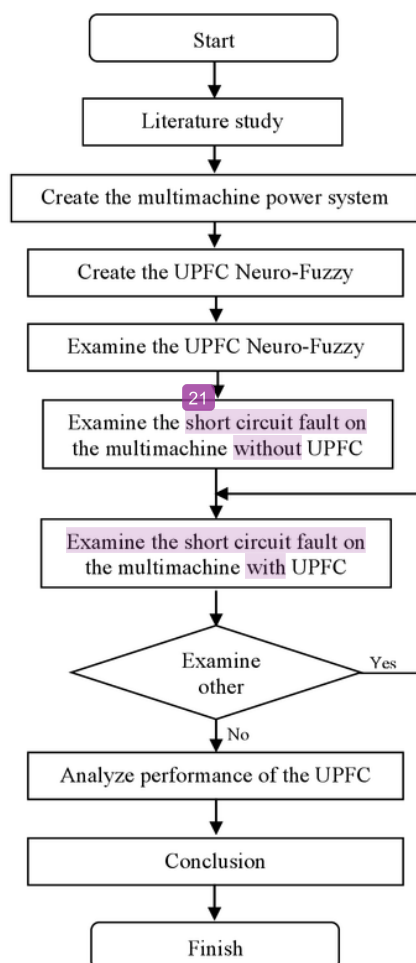

Figure 4. Procedure of the research

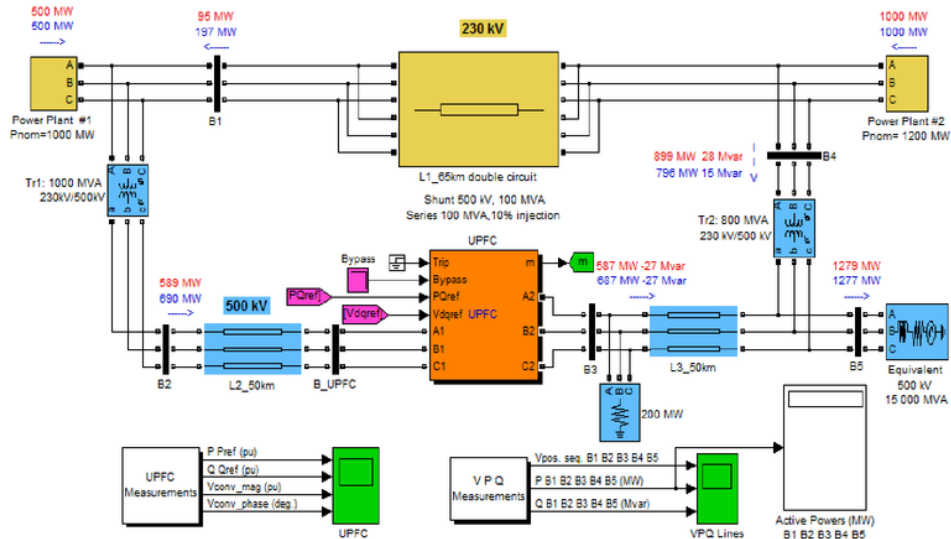

Figure 5. A UPFC model in power transmission systems

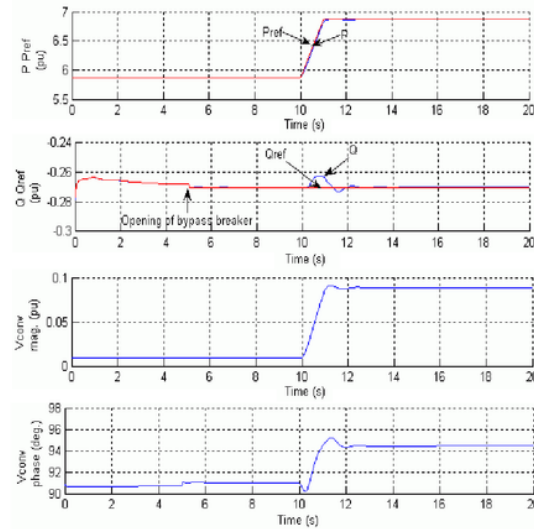

Figure 6. UPFC dynamic responses to changes in load of power system from 587 MW to 687 MW

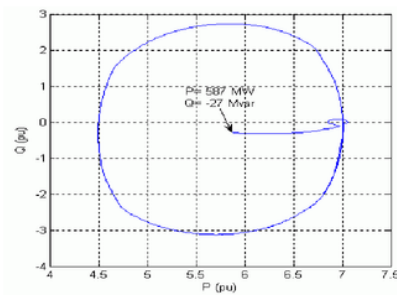

Figure 7. Controllability region of UPFC

Power Flow Control of Power Systems Using UPFC Based on Adaptive Neuro Fuzzy

ORIGINALITY REPORT

64%

SIMILARITY INDEX

%

INTERNET SOURCES

64%

PUBLICATIONS

%

STUDENT PAPERS

PRIMARY SOURCES

1 MORSLI, Sebaa, TAYEB, Allaoui, MOULOUD, Denai and ABDELKADER, Chaker. "A robust adaptive fuzzy control of a unified power flow controller", TUBITAK, 2012. **11%**
Publication

2 T. S. Kamel, M. A. Moustafa Hassan, A. El-Morshedy. "Using a combined Artificial Intelligent Approach in Distance Relay for Transmission line Protection in EPS", 2009 Fifth International Conference on Soft Computing, Computing with Words and Perceptions in System Analysis, Decision and Control, 2009 **9%**
Publication

3 Lütfü Saribulut, Mehmet Tümay. "Simulation Study of Fuzzy Based Unified Power Flow Controller on Power Flow Controlling", 2008 Workshop on Power Electronics and Intelligent Transportation System, 2008 **7%**
Publication

Naqui Anwer, Anwar.S. Siddiqui, Abdullah

4

Umar. "Analysis of UPFC, SSSC with and without POD in congestion management of transmission system", 2012 IEEE 5th India International Conference on Power Electronics (IICPE), 2012

Publication

5%

5

Kobibi Y. I. Djilani, Hadjeri Samir, Zidi Sid Ahmed, Djehaf Mohamed. "Modelling a unified power flow controller for the study of power system steady state and dynamic characteristics", 2013 5th International Conference on Modeling, Simulation and Applied Optimization (ICMSAO), 2013

Publication

3%

6

Abdulkadir Cüneyt Aydın. "Prediction of concrete elastic modulus using adaptive neuro-fuzzy inference system", Civil Engineering and Environmental Systems, 12/1/2006

Publication

3%

7

Mohamed M. Ismail, M. A. Moustafa Hassan. "Using Positive and Negative Sequence Components of Currents and Voltages for High Impedance Fault Analysis via ANFIS", International Journal of System Dynamics Applications, 2012

Publication

3%

8

G. Madhusudhana Rao, V. Anwasha Kumar, B.

2%

V. Sanker Ram. "Design of a neural network based distributed power flow controller (DPFC) for power system stability", 2016 International Conference on Signal Processing, Communication, Power and Embedded System (SCOPEs), 2016

Publication

9

George S. Atsalakis, Ioanna G. Atsalaki, Constantin Zopounidis. "Forecasting the success of a new tourism service by a neuro-fuzzy technique", European Journal of Operational Research, 2018

Publication

2%

10

Shih-Wei Ma, Chang-Huan Kou, Li Chen, An-Pei Wang, Cheng-Yuan Sung. "Application of ANFIS to Stream-Way Transition", 2009 Sixth International Conference on Fuzzy Systems and Knowledge Discovery, 2009

Publication

2%

11

García, . "Reservoir siltation", Dam Maintenance and Rehabilitation II, 2010.

Publication

2%

12

Kuntjoro, Ismail Saud, Didik Harijanto. "Discharge Fluctuation Effect on Meandering River Bed Evolution", IOP Conference Series: Materials Science and Engineering, 2017

Publication

2%

13

Obulesu, Dakka, S.F. Kodad, and B.V. Sanker Ram. "Design and development of a fuzzy coordinated control strategy for faults occurring at different buses in an interconnected power system", International Journal of Computer Applications in Technology, 2011.

Publication

2%

14

M. Ramesh, A. Jaya Laxmi. "Stability of Power Transmission Capability of HVDC system using facts controllers", 2012 International Conference on Computer Communication and Informatics, 2012

Publication

2%

15

Soubhagya Aradyamath, K Kumara, A.D Srinivasan. "Enhanced Performance of Integrated Power System Stabilizer–Effect of Operating Conditions", 2017 International Conference on Current Trends in Computer, Electrical, Electronics and Communication (CTCEEC), 2017

Publication

1%

16

P Manju, V Subbiah. "Intelligent control of Unified Power Flow Controller for stability enhancement of transmission systems", 2010 2nd International Conference on Advanced Computer Control, 2010

Publication

1%

17

Mausam Yadav, Ankur Soni. "Improvement of power flow and voltage stability using unified power flow controller", 2016 International Conference on Electrical, Electronics, and Optimization Techniques (ICEEOT), 2016

Publication

1%

18

S. Baskar, N. Kumarappan, R. Gnanadass. "A novel component minimized converters for unified power flow controller", International Journal of Electrical Power & Energy Systems, 2011

Publication

1%

19

Ramadoni Syahputra, Imam Robandi, Mochamad Ashari. "Reconfiguration of distribution network with DG using fuzzy multi-objective method", 2012 International Conference on Innovation Management and Technology Research, 2012

Publication

1%

20

Karakuzu, C.. "RETRACTED: Fuzzy controller training using particle swarm optimization for nonlinear system control", ISA Transactions, 200804

Publication

1%

21

Syahputra, Ramadoni, and Indah Soesanti. "Power System Stabilizer model based on Fuzzy-PSO for improving power system

1%

stability", 2015 International Conference on Advanced Mechatronics Intelligent Manufacture and Industrial Automation (ICAMIMIA), 2015.

Publication

22

"Advanced Solutions in Power Systems: HVDC, FACTS, and Artificial Intelligence", Wiley, 2016

Publication

1%

23

Wang, K., and M. L. Crow. "Modern flexible AC transmission system (FACTS) devices", Electricity transmission distribution and storage systems, 2013.

Publication

1%

Exclude quotes On

Exclude matches < 1%

Exclude bibliography Off