

LAMPIRAN

LAMPIRAN 1

JUDUL PENELITIAN : PENGARUH EXPERIENTIAL MARKETING TERHADAP LOYALITAS NASABAH MELALUI KEPUASAN NASABAH SEBAGAI VARIABEL INTERVENING

Petunjuk pengisian :

Pada pertanyaan dibawah ini anda diminta untuk mengisi pertanyaan dengan keadaan/ kondisi sebenar benarnya.

Identitas responden

1. Nama/Inisial :
2. Jenis kelamin :
 - a. pria
 - b. wanita
3. Usia saat ini :
 - a. <20 thn
 - b. 20 thn- 30 thn
 - c. 31 thn-40 thn
 - d. 41 thn-50 thn
 - e. >50 thn
4. Pendidikan trakhir :
 - a. sd
 - b.smp
 - c.smu
 - d. diploma
 - e. s1
 - f. s2/s3
5. Pekerjaan saat ini :
 - a. pns
 - c. wiraswasta

- b. peg swata d. TNI/POLRI e. lain-lain
- 6. Sudah berapa lama anda menjadi nasabah BNI syariah cabang Yogyakarta
 - a. < 3 bulan
 - b. 3- 6 bulan
 - c. 6- 12 bulan
 - d. > 2 tahun

Petunjuk pengisian

Pilih jawaban yang menurut anda paling sesuai dengan kondisi yang ada dengan cara memberi tanda (√) pada pilihan jawaban yang tersedia.

Ket :

SS : Sangat setuju

TS : Tidak setuju

S : Setuju

STS: Sangat Tidak Setuju

N : Netral

PANCA INDRA (SENSE)

PERTANYAAN	SS (5)	S (4)	N (3)	TS (2)	STS (1)
1. Desain interior ruangan kantor BNI Syariah cabang DIY sangat unik					
2. Kombinasi warna ruangan kantor BNI Syariah cabang DIY sangat menarik					
3. Seragam yang dikenakan pegawai BNI syariah sangat menarik.					
4. Seragam yang dikenakan pegawai BNI Syariah sudah sesuai syariah					
5. Pengaturan ruangan BNI Syariah sangat rapi					

FEEL (PERASAAN)

PERTANYAAN	SS (5)	S (4)	N (3)	TS (2)	STS (1)
1. Saya merasa mudah memperoleh pelayanan dan bantuan dalam transaksi di BNI Syariah					
2. Mendapatkan pelayanan yang ramah dari para pegawai BNI Syariah cabang DIY					
3. Kebersihan di kantor BNI syariah cabang DIY selalu dijaga					
4. Merasa senang melakukan transaksi di BNI Syariah cabang DIY					
5. Tempat duduk di BNI Syariah cabang DIY nyaman					

THINK (BERFIKIR)

PERTANYAAN	SS (5)	S (4)	N (3)	TS (2)	STS (1)
1. Citra dan keamanan BNI Syariah cabang DIY					

menjadikan saya merasa aman mempercayakan pengelolaan dana saya.					
2. Tertarik dengan kinerja dan pelayanan yang diberikan BNI Syariah cabang DIY.					
3. Ibadah tetap terlaksana dengan adanya mushala di BNI syariah cabang DIY.					
4. Berfikir bahwa BNI Syariah cocok menjadi bank rekomendasi di DIY					
5. Berfikir bahwa BNI syariah sangat sesuai dengan kriteria bank yang saya inginkan					

ACT (KEBIASAAN)

PERTANYAAN	SS (5)	S (4)	N (3)	TS (2)	STS (1)
1. Datang ke BNI Syariah cabang DIY karena sesuai syariah					
2. Datang ke kantor BNI Syariah cabang DIY karena tertarik pelayanannya					

3. Lokasi kantor BNI syariah cabang DIY sangat strategis					
4. Kenyamanan menabung di BNI Syariah cabang DIY membuat saya ingin berbagi pengalaman dengan orang orang terdekat.					
5. Datang ke BNI Syariah cabang DIY karena sebagai salah satu bank terbaik di antara pilihan bank lain					

RELATE (PERTALIAN)

PERTANYAAN	SS (5)	S (4)	N (3)	TS (2)	STS (1)
1. BNI Syariah sebagai tempat menabung semua kalangan.					
2. BNI Syariah sebagai tempat investasi semua kalangan.					
3. BNI Syariah memiliki citra yang baik bagi saya					
4. Bertransaksi di BNI syariah maka saya bagian dari keluarga BNI Syariah cabang DIY					

5. Menabung di BNI Syariah maka maka dapat memperluas jaringan baik dengan pegawai maupun nasabahnya.					
---	--	--	--	--	--

KEPUASAN nasabah

PERTANYAAN	SS (5)	S (4)	N (3)	TS (2)	STS (1)
1. Secara menyeluruh ruangan kantor BNI Syariah cabang DIY sangat memuaskan					
2. Secara menyeluruh pelayanan di kantor BNI Syariah cabang DIY sangat memuaskan.					
3. Secara keseluruhan Menabung maupun investasi di BNI syariah sangat memuaskan harapan saya.					
4. Secara keseluruhan puas menjadi nasabah BNI Syariah dari saya datang					

hingga saya selesai bertransaksi.					
5. BNI Syariah secara menyeluruh telah sesuai harapan/ standar saya					

LOYALITAS nasabah

PERTANYAAN	SS (5)	S (4)	N (3)	TS (2)	STS (1)
1. Sudah menabung di BNI Syariah cabang DIY lebih sering					
2. Sudah membuka tabungan lain (haji, dll) BNI Syariah cabang DIY dengan sengaja					
3. Sudah memilih BNI syariah menjadi pilihan utama daripada bank lainnya.					
4. tidak akan beralih ke produk bank lain selain BNI syariah cabang DIY					
5. Sudah mengajak teman keluarga untuk ikut serta menjadi nasabah BNI Syariah cabang DIY.					

LAMPIRAN 2

STATISTIK DESKRPTIF

Descriptive Statistics

	N	Minimum	Maximum	Mean	Std. Deviation
SE1	118	2	5	3,77	,778
SE2	118	2	5	3,78	,730
SE3	118	2	5	3,73	,747
SE4	118	2	5	3,85	,747
SE5	118	2	5	3,81	,787
Valid N (listwise)	118				

Descriptive Statistics

	N	Minimum	Maximum	Mean	Std. Deviation
FE1	118	2	5	3,75	,847
FE2	118	2	5	3,81	,762
FE3	118	2	5	3,84	,827
FE4	118	2	5	3,79	,761
FE5	118	2	5	3,79	,825
Valid N (listwise)	118				

Descriptive Statistics

	N	Minimum	Maximum	Mean	Std. Deviation
TH1	118	2	5	4,00	,740
TH2	118	2	5	3,92	,753
TH3	118	3	5	4,03	,703
TH4	118	3	5	4,05	,702
TH5	118	3	5	3,96	,709
Valid N (listwise)	118				

Descriptive Statistics

	N	Minimum	Maximum	Mean	Std. Deviation
AC1	118	2	5	3,77	,919
AC2	118	2	5	3,77	,851
AC3	118	2	5	3,79	,885

AC4	118	2	5	3,75	,847
AC5	118	2	5	3,75	,837
Valid N (listwise)	118				

Descriptive Statistics

	N	Minimum	Maximum	Mean	Std. Deviation
RE1	118	2	5	3,74	,672
RE2	118	2	5	3,80	,711
RE3	118	2	5	3,71	,775
RE4	118	2	5	3,70	,755
RE5	118	2	5	3,77	,744
Valid N (listwise)	118				

Descriptive Statistics

	N	Minimum	Maximum	Mean	Std. Deviation
KE1	118	2	5	3,92	,786
KE2	118	2	5	3,98	,816
KE3	118	2	5	4,01	,862
KE4	118	2	5	3,98	,784
KE5	118	2	5	3,97	,847
Valid N (listwise)	118				

Descriptive Statistics

	N	Minimum	Maximum	Mean	Std. Deviation
LO1	118	2	5	3,96	,709
LO2	118	2	5	3,98	,784
LO3	118	2	5	4,00	,728
LO4	118	2	5	3,97	,826
LO5	118	2	5	4,00	,740
Valid N (listwise)	118				

LAMPIRAN 3

MODEL PENELITIAN

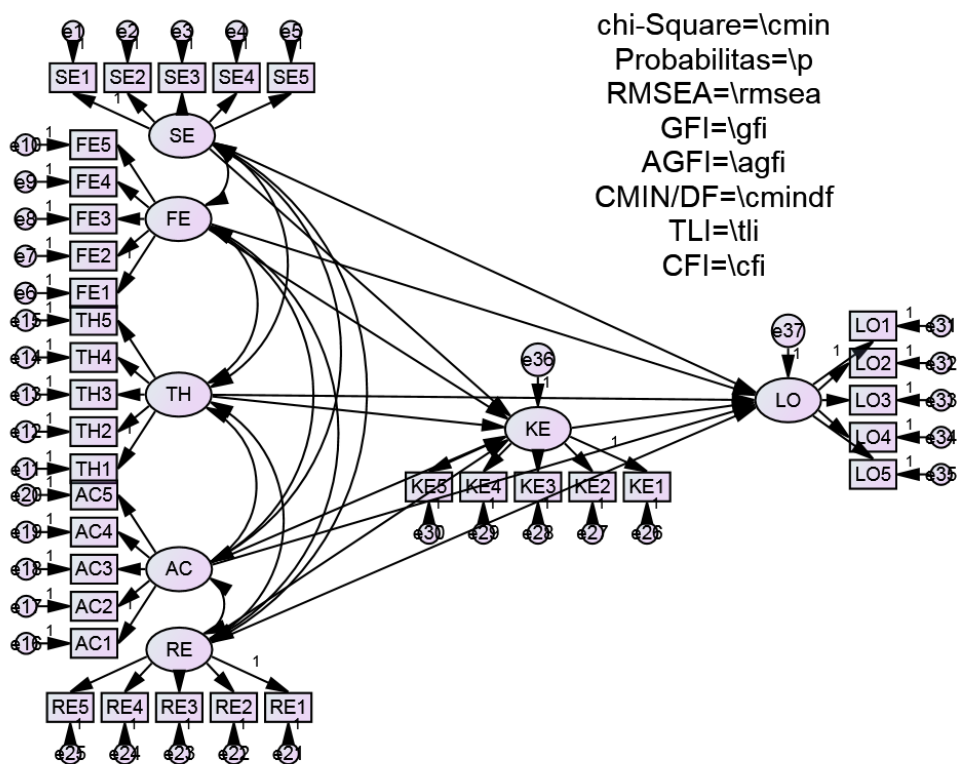

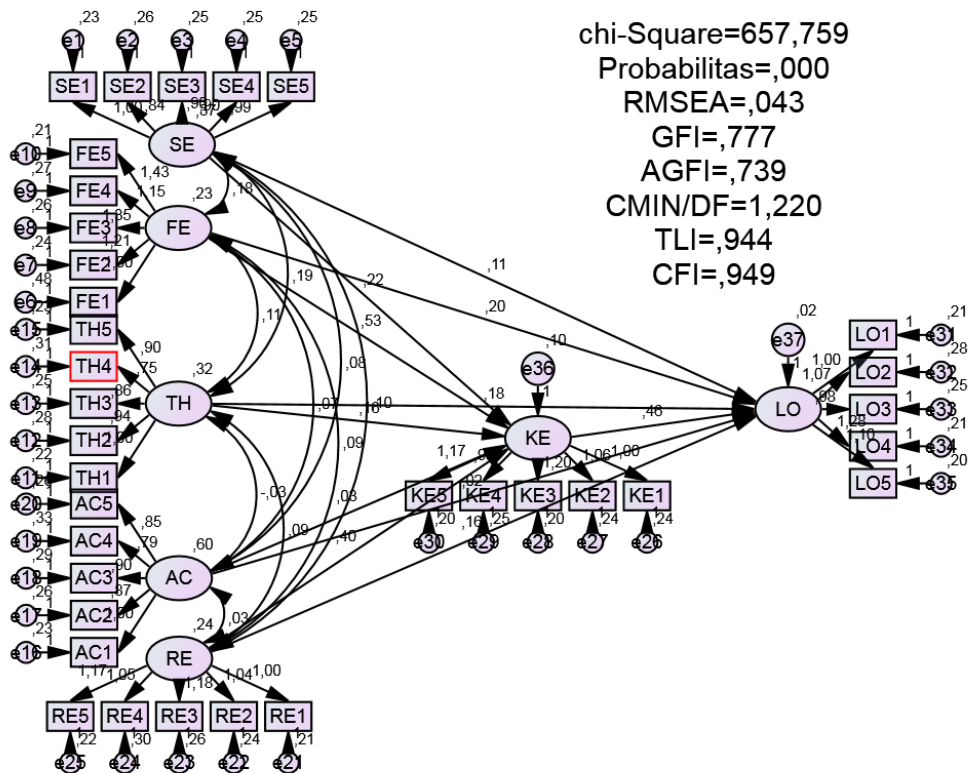

UJI VALIDITAS

Standardized Regression Weights: (Group number 1 - Default model)

	Estimate
KE <--- SE	,220
KE <--- FE	,412
KE <--- TH	,152
KE <--- AC	,034
KE <--- RE	,321
LO <--- SE	,121
LO <--- FE	,182
LO <--- TH	,189
LO <--- AC	-,034
LO <--- RE	,148
LO <--- KE	,529
SE1 <--- SE	,790
SE2 <--- SE	,709
SE3 <--- SE	,743
SE4 <--- SE	,742

	Estimate
SE5 <--- SE	,771
FE1 <--- FE	,565
FE2 <--- FE	,762
FE3 <--- FE	,784
FE4 <--- FE	,726
FE5 <--- FE	,832
TH1 <--- TH	,774
TH2 <--- TH	,713
TH3 <--- TH	,703
TH4 <--- TH	,611
TH5 <--- TH	,728
AC1 <--- AC	,848
AC2 <--- AC	,799
AC3 <--- AC	,795
AC4 <--- AC	,730
AC5 <--- AC	,793
RE1 <--- RE	,735
RE2 <--- RE	,720
RE3 <--- RE	,755
RE4 <--- RE	,689
RE5 <--- RE	,778
KE1 <--- KE	,782
KE2 <--- KE	,800
KE3 <--- KE	,853
KE4 <--- KE	,767
KE5 <--- KE	,847
LO1 <--- LO	,758
LO2 <--- LO	,731
LO3 <--- LO	,721
LO4 <--- LO	,832
LO5 <--- LO	,800

DEGREE OF FREEDOM

Computation of degrees of freedom (Default model)

Number of distinct sample moments:	630
Number of distinct parameters to be estimated:	91
Degrees of freedom (630 - 91):	539

UJI NORMALITAS

Assessment of normality (Group number 1)

Variable	min	max	skew	c.r.	kurtosis	c.r.
LO5	2,000	5,000	-,255	-1,129	-,465	-1,031
LO4	2,000	5,000	-,302	-1,341	-,692	-1,534
LO3	2,000	5,000	-,134	-,592	-,728	-1,615
LO2	2,000	5,000	-,291	-1,289	-,567	-1,258
LO1	2,000	5,000	-,374	-1,658	,132	,293
KE5	2,000	5,000	-,445	-1,974	-,464	-1,029
KE4	2,000	5,000	-,397	-1,763	-,303	-,672
KE3	2,000	5,000	-,418	-1,853	-,692	-1,534
KE2	2,000	5,000	-,253	-1,122	-,811	-1,798
KE1	2,000	5,000	-,290	-1,285	-,440	-,975
RE5	2,000	5,000	-,231	-1,024	-,187	-,415
RE4	2,000	5,000	,187	,829	-,660	-1,463
RE3	2,000	5,000	,102	,451	-,640	-1,419
RE2	2,000	5,000	,169	,749	-,742	-1,646
RE1	2,000	5,000	-,147	-,652	-,082	-,182
AC5	2,000	5,000	-,306	-1,358	-,423	-,939
AC4	2,000	5,000	-,359	-1,594	-,397	-,880
AC3	2,000	5,000	-,168	-,746	-,803	-1,781
AC2	2,000	5,000	-,214	-,947	-,606	-1,344
AC1	2,000	5,000	-,263	-1,165	-,778	-1,725
TH5	3,000	5,000	,060	,265	-,993	-2,201
TH4	3,000	5,000	-,070	-,310	-,955	-2,118
TH3	3,000	5,000	-,047	-,207	-,961	-2,131
TH2	2,000	5,000	,005	,020	-,941	-2,085
TH1	2,000	5,000	-,127	-,565	-,811	-1,797
FE5	2,000	5,000	,042	,188	-,889	-1,971
FE4	2,000	5,000	-,094	-,419	-,466	-1,034
FE3	2,000	5,000	-,242	-1,071	-,558	-1,237
FE2	2,000	5,000	,092	,408	-,818	-1,815
FE1	2,000	5,000	-,105	-,465	-,704	-1,561
SE5	2,000	5,000	-,065	-,290	-,635	-1,408
SE4	2,000	5,000	-,118	-,523	-,469	-1,040
SE3	2,000	5,000	-,010	-,046	-,456	-1,011
SE2	2,000	5,000	,230	1,022	-,846	-1,877
SE1	2,000	5,000	,201	,891	-,917	-2,034
Multivariate					-,982	-,105

UJI OUTLIER

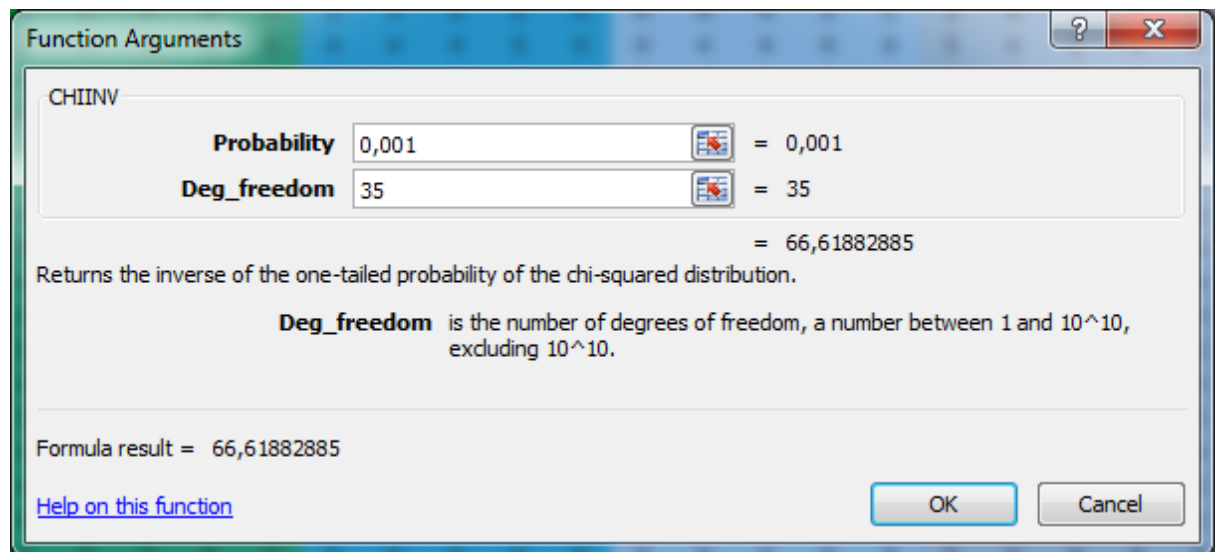

Observations farthest from the centroid (Mahalanobis distance) (Group number 1)

Observation number	Mahalanobis d-squared	p1	p2
82	50,462	,044	,995
69	48,888	,060	,994
49	47,716	,074	,994
32	47,375	,079	,986
99	46,573	,091	,986
67	46,527	,092	,966
44	46,452	,093	,931
6	45,134	,117	,973
20	44,838	,123	,962
25	44,362	,133	,961
17	43,615	,151	,975
15	42,990	,166	,983
16	42,619	,176	,982
101	42,248	,186	,982
68	42,192	,188	,970
105	41,995	,194	,961
57	41,947	,195	,939
34	41,628	,204	,939
10	41,488	,209	,921
80	41,307	,214	,906
60	41,003	,224	,908
87	40,936	,226	,874
75	40,850	,229	,839

Observation number	Mahalanobis d-squared	p1	p2
45	40,714	,233	,809
14	40,327	,246	,836
106	40,284	,248	,786
79	40,256	,249	,725
108	40,097	,254	,698
61	39,958	,259	,665
63	39,918	,261	,598
81	39,608	,272	,623
86	39,595	,272	,546
89	39,527	,275	,488
72	39,448	,278	,434
113	39,392	,280	,375
76	39,171	,288	,375
98	39,149	,289	,309
33	38,630	,309	,413
114	38,349	,320	,439
56	38,271	,323	,391
70	38,094	,330	,380
88	38,085	,331	,312
42	38,029	,333	,264
52	38,027	,333	,206
64	37,969	,336	,169
38	37,935	,337	,132
95	37,659	,349	,150
27	37,482	,356	,146
40	37,109	,372	,190
18	36,825	,384	,216
103	36,640	,393	,215
1	36,485	,400	,206
115	36,484	,400	,157
12	36,467	,400	,120
9	36,315	,407	,114
78	36,118	,416	,117
53	36,114	,416	,085
91	36,102	,417	,061
83	36,101	,417	,042
90	36,049	,419	,031
41	35,750	,433	,041
116	35,486	,445	,049
94	35,448	,447	,036

Observation number	Mahalanobis d-squared	p1	p2
13	35,400	,449	,027
46	35,229	,457	,026
84	35,202	,459	,018
39	34,989	,469	,020
71	34,879	,474	,016
62	34,785	,478	,013
117	34,468	,494	,019
37	34,417	,496	,014
104	33,831	,524	,038
19	33,571	,537	,045
102	33,386	,546	,046
97	33,374	,547	,032
92	33,338	,548	,022
77	33,309	,550	,015
2	33,267	,552	,010
7	32,692	,580	,029
21	32,530	,588	,028
100	32,094	,609	,050
28	31,428	,641	,131
29	31,098	,657	,168
65	30,637	,679	,253
58	30,605	,680	,203
24	30,531	,684	,170
5	30,065	,705	,256
31	29,906	,712	,245
85	29,696	,722	,250
51	29,390	,735	,289
93	29,219	,743	,279
109	29,139	,746	,236
55	28,987	,753	,219
96	28,914	,756	,179
30	28,895	,757	,131
22	28,691	,765	,129
107	28,313	,781	,167
36	28,275	,783	,123
112	28,167	,787	,099
4	28,028	,792	,083

MODEL FIT

CMIN

Model	NPAR	CMIN	DF	P	CMIN/DF
Default model	91	657,759	539	,000	1,220
Saturated model	630	,000	0		
Independence model	35	2935,794	595	,000	4,934

RMR, GFI

Model	RMR	GFI	AGFI	PGFI
Default model	,034	,777	,739	,665
Saturated model	,000	1,000		
Independence model	,209	,189	,141	,179

Baseline Comparisons

Model	NFI Delta1	RFI rho1	IFI Delta2	TLI rho2	CFI
Default model	,776	,753	,950	,944	,949
Saturated model	1,000		1,000		1,000
Independence model	,000	,000	,000	,000	,000

RMSEA

Model	RMSEA	LO 90	HI 90	PCLOSE
Default model	,043	,030	,055	,826
Independence model	,183	,177	,190	,000

UJI HIPOTESIS

Regression Weights: (Group number 1 - Default model)

	Estimate	S.E.	C.R.	P	Label
KE <--- SE	,220	,102	2,152	,031	par_29
KE <--- FE	,529	,145	3,647	***	par_30
KE <--- TH	,164	,095	1,717	,086	par_31
KE <--- AC	,026	,053	,502	,616	par_32
KE <--- RE	,399	,102	3,929	***	par_33
LO <--- SE	,106	,070	1,513	,130	par_34
LO <--- FE	,205	,103	1,994	,046	par_35
LO <--- TH	,177	,067	2,641	,008	par_36
LO <--- AC	-,024	,034	-,682	,496	par_37
LO <--- RE	,161	,077	2,097	,036	par_38
LO <--- KE	,463	,112	4,124	***	par_39
SE1 <--- SE	1,000				
SE2 <--- SE	,842	,109	7,723	***	par_1
SE3 <--- SE	,904	,108	8,389	***	par_2
SE4 <--- SE	,902	,109	8,236	***	par_3
SE5 <--- SE	,988	,114	8,646	***	par_4
FE1 <--- FE	1,000				
FE2 <--- FE	1,213	,206	5,890	***	par_5
FE3 <--- FE	1,354	,226	5,982	***	par_6
FE4 <--- FE	1,154	,196	5,894	***	par_7
FE5 <--- FE	1,434	,230	6,231	***	par_8
TH1 <--- TH	1,000				
TH2 <--- TH	,938	,126	7,419	***	par_9
TH3 <--- TH	,864	,119	7,263	***	par_10
TH4 <--- TH	,750	,116	6,447	***	par_11
TH5 <--- TH	,901	,121	7,466	***	par_12
AC1 <--- AC	1,000				
AC2 <--- AC	,872	,088	9,910	***	par_13
AC3 <--- AC	,903	,092	9,838	***	par_14
AC4 <--- AC	,793	,091	8,721	***	par_15
AC5 <--- AC	,851	,084	10,136	***	par_16
RE1 <--- RE	1,000				
RE2 <--- RE	1,037	,147	7,074	***	par_17
RE3 <--- RE	1,185	,164	7,203	***	par_18
RE4 <--- RE	1,053	,154	6,847	***	par_19
RE5 <--- RE	1,172	,145	8,096	***	par_20
KE1 <--- KE	1,000				

	Estimate	S.E.	C.R.	P	Label
KE2 <--- KE	1,063	,114	9,331	***	par_21
KE3 <--- KE	1,197	,118	10,168	***	par_22
KE4 <--- KE	,979	,108	9,054	***	par_23
KE5 <--- KE	1,167	,115	10,154	***	par_24
LO1 <--- LO	1,000				
LO2 <--- LO	1,068	,131	8,161	***	par_25
LO3 <--- LO	,978	,123	7,982	***	par_26
LO4 <--- LO	1,280	,133	9,605	***	par_27
LO5 <--- LO	1,102	,121	9,127	***	par_28

Standardized Direct Effects (Group number 1 - Default model)

	RE	AC	TH	FE	SE	KE	LO
KE	,321	,034	,152	,412	,220	,000	,000
LO	,148	-,034	,189	,182	,121	,529	,000
LO5	,000	,000	,000	,000	,000	,000	,800
LO4	,000	,000	,000	,000	,000	,000	,832
LO3	,000	,000	,000	,000	,000	,000	,721
LO2	,000	,000	,000	,000	,000	,000	,731
LO1	,000	,000	,000	,000	,000	,000	,758
KE5	,000	,000	,000	,000	,000	,847	,000
KE4	,000	,000	,000	,000	,000	,767	,000
KE3	,000	,000	,000	,000	,000	,853	,000
KE2	,000	,000	,000	,000	,000	,800	,000
KE1	,000	,000	,000	,000	,000	,782	,000
RE5	,778	,000	,000	,000	,000	,000	,000
RE4	,689	,000	,000	,000	,000	,000	,000
RE3	,755	,000	,000	,000	,000	,000	,000
RE2	,720	,000	,000	,000	,000	,000	,000
RE1	,735	,000	,000	,000	,000	,000	,000
AC5	,000	,793	,000	,000	,000	,000	,000
AC4	,000	,730	,000	,000	,000	,000	,000
AC3	,000	,795	,000	,000	,000	,000	,000
AC2	,000	,799	,000	,000	,000	,000	,000
AC1	,000	,848	,000	,000	,000	,000	,000
TH5	,000	,000	,728	,000	,000	,000	,000
TH4	,000	,000	,611	,000	,000	,000	,000
TH3	,000	,000	,703	,000	,000	,000	,000
TH2	,000	,000	,713	,000	,000	,000	,000
TH1	,000	,000	,774	,000	,000	,000	,000
FE5	,000	,000	,000	,832	,000	,000	,000
FE4	,000	,000	,000	,726	,000	,000	,000
FE3	,000	,000	,000	,784	,000	,000	,000
FE2	,000	,000	,000	,762	,000	,000	,000
FE1	,000	,000	,000	,565	,000	,000	,000
SE5	,000	,000	,000	,000	,771	,000	,000
SE4	,000	,000	,000	,000	,742	,000	,000
SE3	,000	,000	,000	,000	,743	,000	,000
SE2	,000	,000	,000	,000	,709	,000	,000
SE1	,000	,000	,000	,000	,790	,000	,000

Standardized Indirect Effects (Group number 1 - Default model)

	RE	AC	TH	FE	SE	KE	LO
KE	,000	,000	,000	,000	,000	,000	,000
LO	,170	,018	,081	,218	,116	,000	,000
LO5	,254	-,013	,216	,320	,190	,423	,000
LO4	,264	-,014	,224	,333	,197	,440	,000
LO3	,229	-,012	,195	,289	,171	,382	,000
LO2	,233	-,012	,197	,293	,174	,387	,000
LO1	,241	-,012	,204	,304	,180	,401	,000
KE5	,271	,028	,129	,349	,186	,000	,000
KE4	,246	,026	,117	,316	,168	,000	,000
KE3	,273	,029	,130	,352	,187	,000	,000
KE2	,257	,027	,122	,330	,176	,000	,000
KE1	,251	,026	,119	,322	,172	,000	,000
RE5	,000	,000	,000	,000	,000	,000	,000
RE4	,000	,000	,000	,000	,000	,000	,000
RE3	,000	,000	,000	,000	,000	,000	,000
RE2	,000	,000	,000	,000	,000	,000	,000
RE1	,000	,000	,000	,000	,000	,000	,000
AC5	,000	,000	,000	,000	,000	,000	,000
AC4	,000	,000	,000	,000	,000	,000	,000
AC3	,000	,000	,000	,000	,000	,000	,000
AC2	,000	,000	,000	,000	,000	,000	,000
AC1	,000	,000	,000	,000	,000	,000	,000
TH5	,000	,000	,000	,000	,000	,000	,000
TH4	,000	,000	,000	,000	,000	,000	,000
TH3	,000	,000	,000	,000	,000	,000	,000
TH2	,000	,000	,000	,000	,000	,000	,000
TH1	,000	,000	,000	,000	,000	,000	,000
FE5	,000	,000	,000	,000	,000	,000	,000
FE4	,000	,000	,000	,000	,000	,000	,000
FE3	,000	,000	,000	,000	,000	,000	,000
FE2	,000	,000	,000	,000	,000	,000	,000
FE1	,000	,000	,000	,000	,000	,000	,000
SE5	,000	,000	,000	,000	,000	,000	,000
SE4	,000	,000	,000	,000	,000	,000	,000
SE3	,000	,000	,000	,000	,000	,000	,000
SE2	,000	,000	,000	,000	,000	,000	,000
SE1	,000	,000	,000	,000	,000	,000	,000

SURAT KETERANGAN
YGS/01/ 1010 /2019

Bismillahirrahmanirrahiim

Yang bertanda-tangan di bawah ini :

Nama : Arief Mursidi
Jabatan : Operational Manager
PT Bank BNI Syariah
Kantor Cabang Yogyakarta

Menerangkan bahwa :

Nama : Sintiya
No Mhs. : 20150730042
Fakultas/Prodi : Agama Islam/Ekonomi Syariah
Universitas / PT : Universitas Muhammadiyah Yogyakarta

Adalah benar telah melaksanakan Penelitian untuk menyelesaikan skripsi jenjang S-1 di PT. Bank BNI Syariah Kantor Cabang Yogyakarta dengan judul **"Pengaruh Strategi Experiential Marketing Terhadap Loyalitas Nasabah Melalui Kepuasan Nasabah Sebagai Variabel Intervening (Studi Kasus Pada Bank BNI Syariah Cabang Yogyakarta)"**

Demikianlah surat keterangan ini kami buat untuk dapat dipergunakan semestinya.

Yogyakarta, 12 JUL 2019

PT Bank BNI Syariah
Kantor Cabang Yogyakarta



Arief Mursidi
Operational Manager

PERPUSTAKAAN
UNIVERSITAS MUHAMMADIYAH YOGYAKARTA (UMY)
Terakreditasi "A" (Perpustakaan Nasional RI No : 29/1/ee/XII.2014)

Perpustakaan Universitas Muhammadiyah Yogyakarta menyatakan bahwa atas nama :

Nama : Sintiya
Prodi/Fakultas : Ekonomi Syariah/Agama Islam
NIM : 20150730042
Judul : Pengaruh Strategi Experiential Marketing Terhadap Loyalitas Melalui Kepuasan Sebagai Variabel Intervening Pada Bank BNI Syariah Yogyakarta
Dosen Pembimbing : Dyah Pikanti Diwanti S.E.,M.M.

Telah dilakukan tes Turnitin filter 1%, dengan tingkat similaritasnya sebesar **17%**.
Semoga surat keterangan ini dapat digunakan sebagaimana mestinya.

Mengetahui
Ka.Ur. Pengolahan dan Layanan



Laela Niswatin,S.I.Pust.

Yogyakarta, 2019-07-02
yang melaksanakan pengecekan



Raisa Fadelina