

LAMPIRAN

Lampiran 1 Hasil uji tarik spesimen variasi kecepatan putar tool 588 RPM (1)

Testometric
materials testing machines

winTest™
Analysis

POLYPROPYLENE
588 rpm(1)

Ref 1 :
Ref 2 :
Ref 3 :

Test Name : ASTM D638
komposit Test Type : Tensile
Test Date : 30/04/2019
9:37 Test Speed :
10,000 mm/min
Pretension : 5,000 N
Sample Length : 120,000 mm

Test No	Elong. @ Peak (mm)	Force @ peak (N)
1	4,367	1240,800

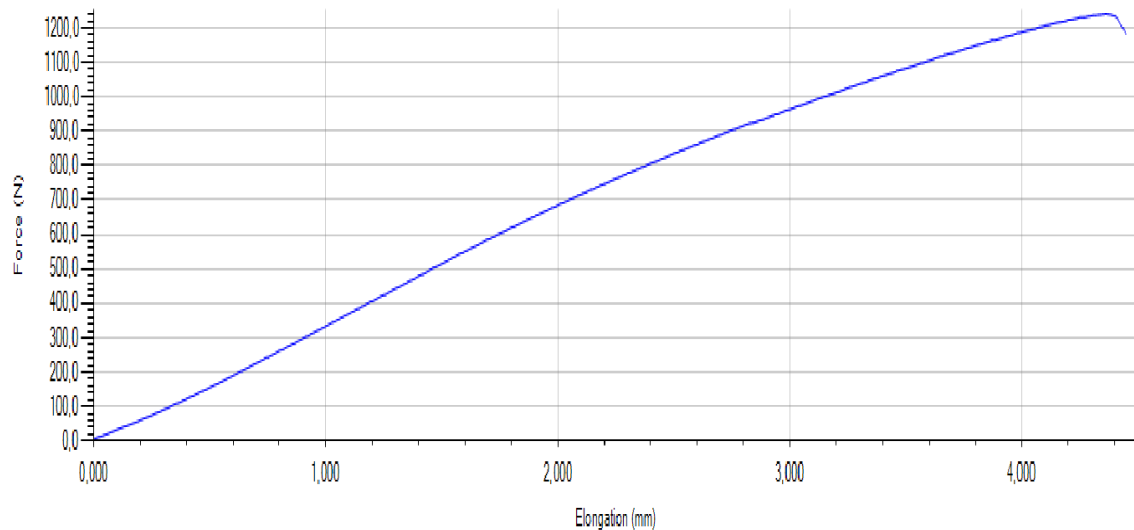

— Test 1



Unit 1 Lincoln Business Park Lincoln Close,
Rochdale, Lancashire, England OL11 1NR

Tel: (44) (0)1706 654039 Fax: (44) (0)1706 646089
Email: info@testometric.co.uk website: www.testometric.co.uk

Lampiran 2 Hasil uji tarik spesimen variasi kecepatan putar tool 588 RPM (2)

Testometric
materials testing machines

winTest™
Analysis

POLYPROPYLENE
588 rpm(2)

Ref 1 :
Ref 2 :
Ref 3 :

Test Name : ASTM D638 komposit
Test Type : Tensile
Test Date : 30/04/2019 9:40
Test Speed : 10,000 mm/min
Pretension : 5,000 N
Sample Length : 120,000 mm

Test No	Elong. @ Peak (mm)	Force @ peak (N)
1	4,089	1228,700

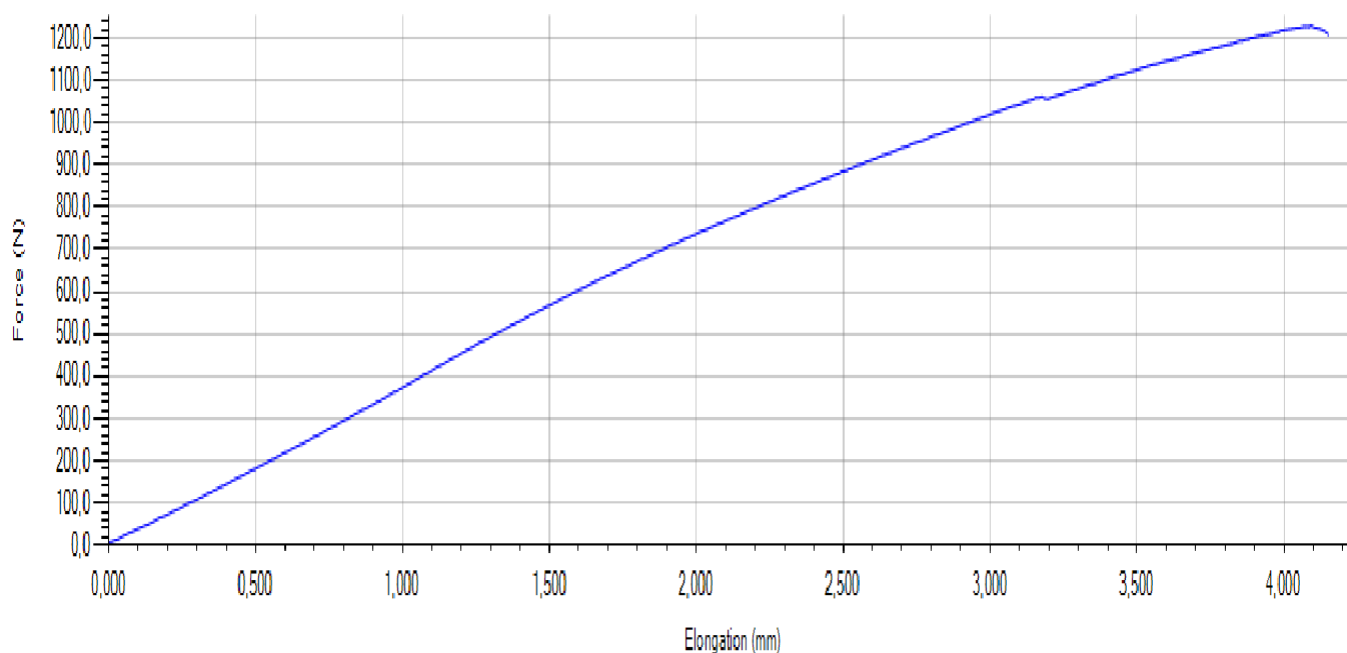

— Test 1



Unit 1 Lincoln Business Park Lincoln Close,
Rochdale, Lancashire, England OL11 1NR

Tel: (44) (0)1706 654039 Fax: (44) (0)1706 646089
Email: info@testometric.co.uk website: www.testometric.co.uk

Lampiran 3 Hasil uji tarik spesimen variasi kecepatan putar tool 977 RPM (1)

Testometric
materials testing machines

winTest™
Analysis

POLYPROPYLENE
977 rpm(1)

Ref 1 :
Ref 2 :
Ref 3 :

Test Name : ASTM D638 komposit
Test Type : Tensile
Test Date : 30/04/2019 10:01
Test Speed : 10,000 mm/min
Pretension : 5,000 N
Sample Length : 120,000 mm

Test No	Elong. @ Peak (mm)	Force @ peak (N)
1	8,447	1853,600

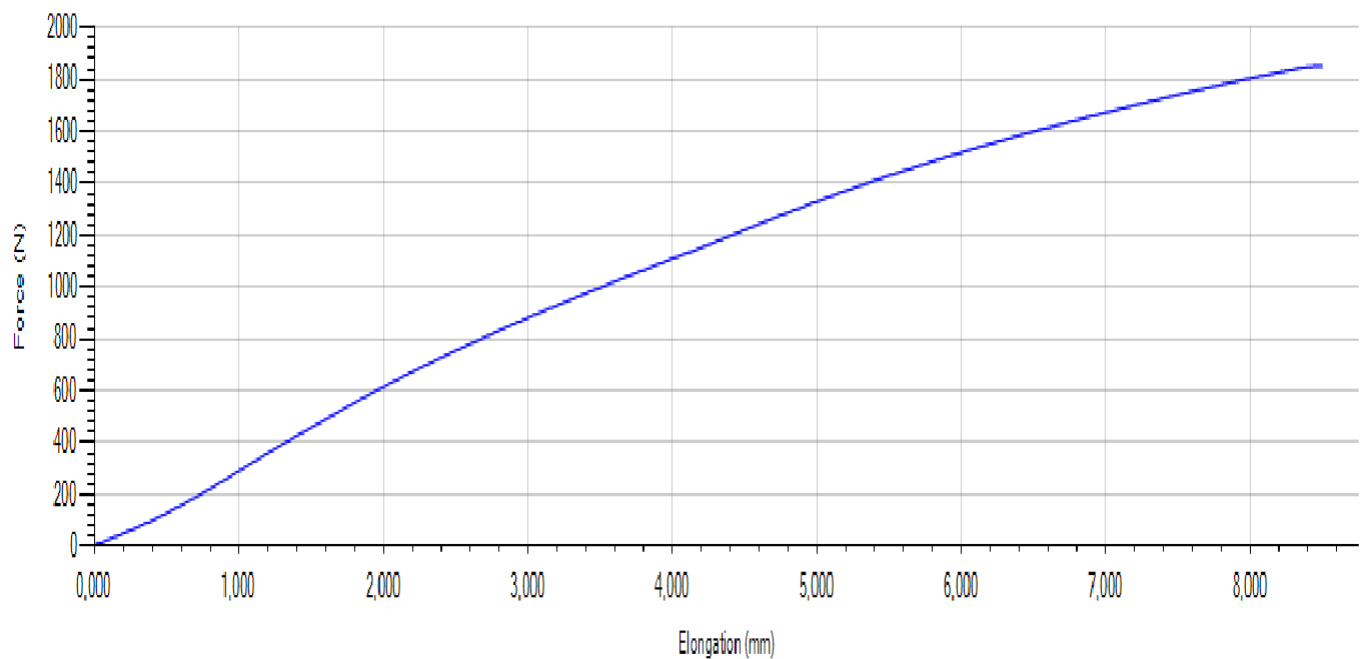

— Test 1



Unit 1 Lincoln Business Park Lincoln Close,
Rochdale, Lancashire, England OL11 1NR

Tel: (44) (0)1706 654039 Fax: (44) (0)1706 646089
Email: info@testometric.co.uk website: www.testometric.co.uk

Lampiran 4 Hasil uji tarik spesimen variasi kecepatan putar tool 977 RPM (2)

Testometric
materials testing machines

winTest™
Analysis

POLYPROPYLENE
977 rpm(2)

Ref 1 : Test Name : ASTM D638 komposit
 Ref 2 : Test Type : Tensile
 Ref 3 : Test Date : 30/04/2019 10:05
 Test Speed : 10,000 mm/min
 Pretension : 5,000 N
 Sample Length : 120,000 mm

Test No	Elong. @ Peak (mm)	Force @ peak (N)
1	8,539	1875,800

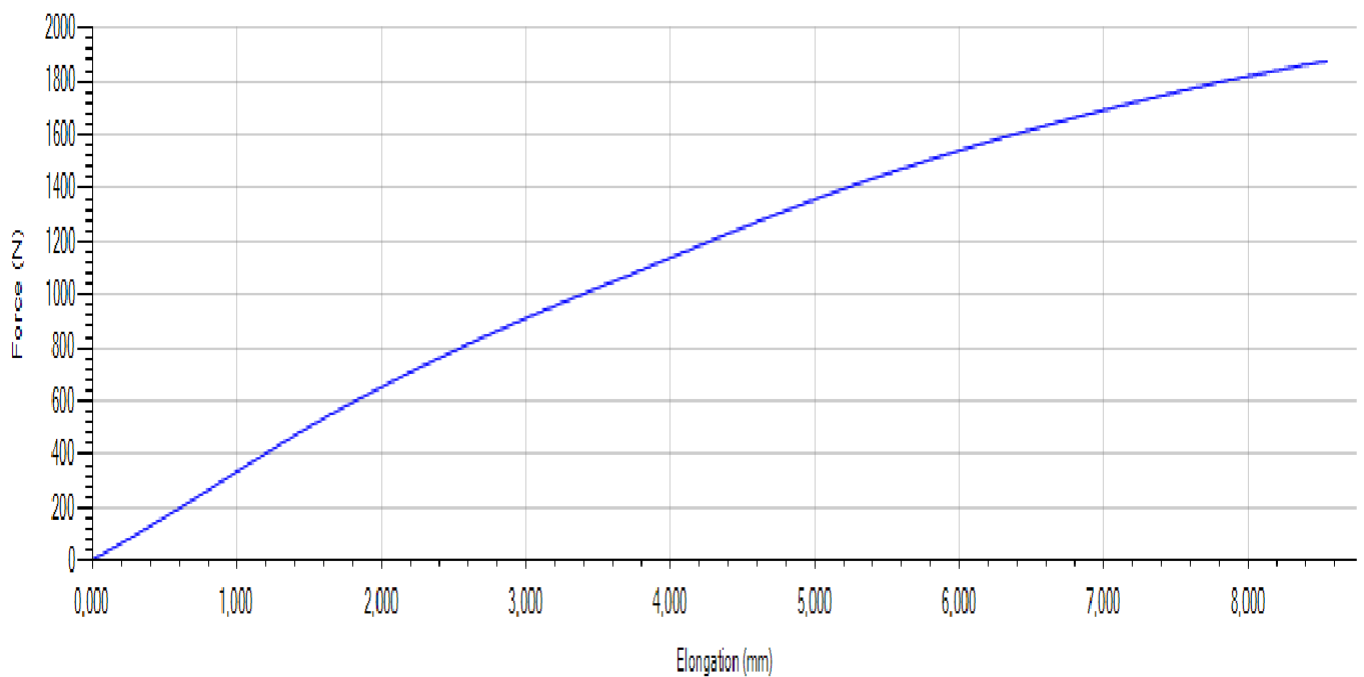

— Test 1

Lampiran 5 Hasil uji tarik spesimen variasi kecepatan putar tool 1562 RPM (1)

Testometric
materials testing machines

winTest™
Analysis

POLYPROPYLENE
1562 rpm(1)

Ref 1 :
Ref 2 :
Ref 3 :

Test Name : ASTM D638 komposit
Test Type : Tensile
Test Date : 30/04/2019 09:27
Test Speed : 10,000 mm/min
Pretension : 5,000 N
Sample Length : 120,000 mm

Test No	Elong. @ Peak (mm)	Force @ peak (N)
1	6,283	1611,700

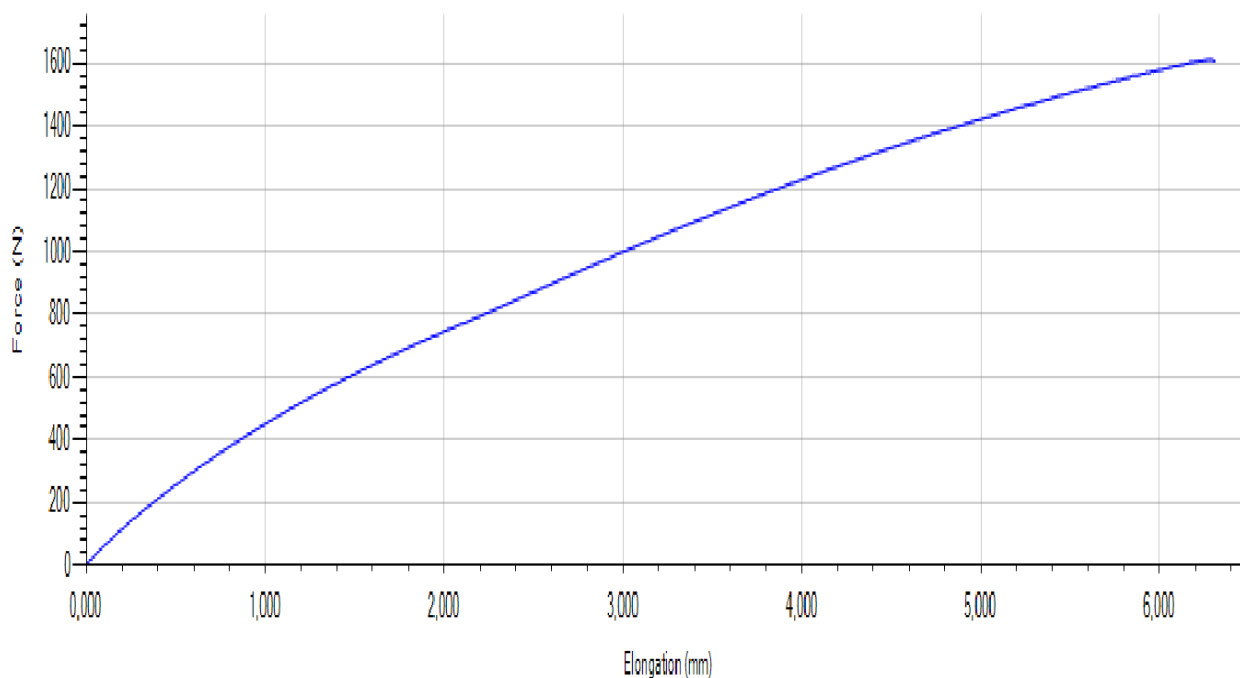

— Test 1



Rochdale, Lancashire, England OL11 1NR

Email: info@testometric.co.uk website: www.testometric.co.uk

Lampiran 6 Hasil uji tarik spesimen variasi kecepatan putar tool 1562 RPM (2)

Testometric
materials testing machines

winTest™
Analysis

POLYPROPYLENE
1562 rpm(2)

Ref 1 :
Ref 2 :
Ref 3 :

Test Name : ASTM D638 komposit
Test Type : Tensile
Test Date : 30/04/2019 09:30
Test Speed : 10,000 mm/min
Pretension : 5,000 N
Sample Length : 120,000 mm

Test No	Elong. @ Peak (mm)	Force @ peak (N)
1	7,517	1510,300

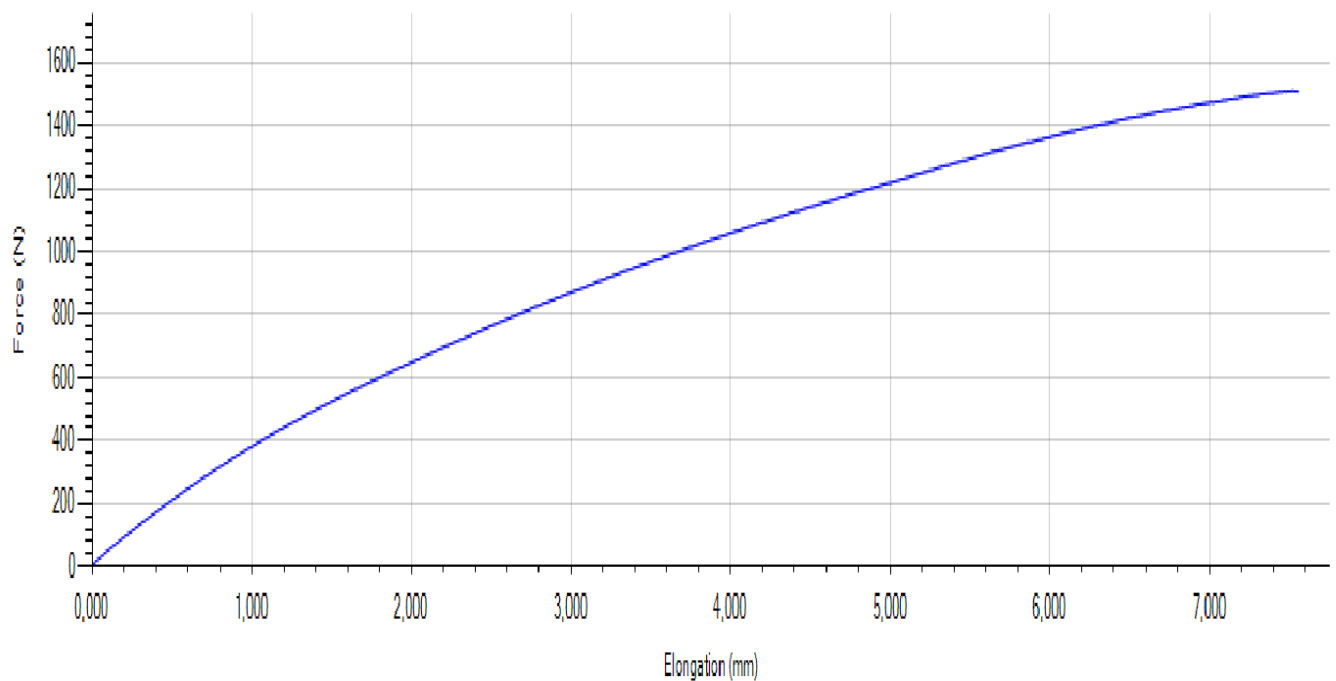

— Test 1



Unit 1 Lincoln Business Park Lincoln Close,
Rochdale, Lancashire, England OL11 1NR

Tel: (44) (0)1706 654039 Fax: (44) (0)1706 646089
Email: info@testometric.co.uk website: www.testometric.co.uk

Lampiran 7 Hasil uji tarik spesimen variasi kecepatan putar tool 2371 RPM (1)

Testometric
materials testing machines

winTest™
Analysis

POLYPROPYLENE
2371 rpm(1)

Ref 1 :
Ref 2 :
Ref 3 :

Test Name : ASTM D638 komposit
Test Type : Tensile
Test Date : 30/04/2019 09:17
Test Speed : 10,000 mm/min
Pretension : 5,000 N
Sample Length : 120,000 mm

Test No	Elong. @ Peak (mm)	Force @ peak (N)
---------	-----------------------	---------------------

1	6.235	1575.8111
---	-------	-----------

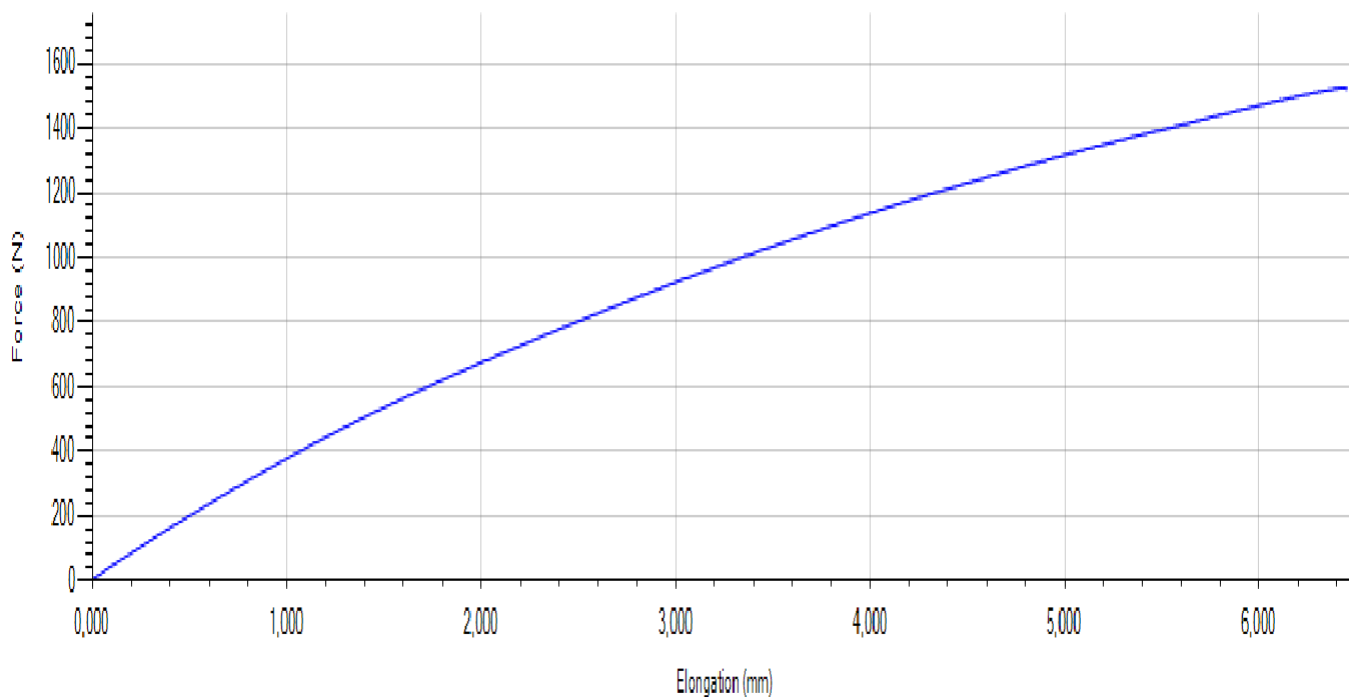

— Test 1



Unit 1 Lincoln Business Park Lincoln Close,
Rochdale, Lancashire, England OL11 1NR

Tel: (44) (0)1706 654039 Fax: (44) (0)1706 646089
Email: info@testometric.co.uk website: www.testometric.co.uk

Lampiran 8 Hasil uji tarik spesimen variasi kecepatan putar tool 2371 RPM (2)

Testometric
materials testing machines

winTest™
Analysis

POLYPROPYLENE Type : Tensile
2371 rpm Test Date : 30/04/2019 09:21
Test Speed : 10,000 mm/min
Pretension : 5,000 N
Sample Length : 120,000 mm

Ref 1 :
Ref 2 :
Ref 3 :

Test No	Elong. @ Peak (mm)	Force @ peak (N)
1	7,625	1672,600

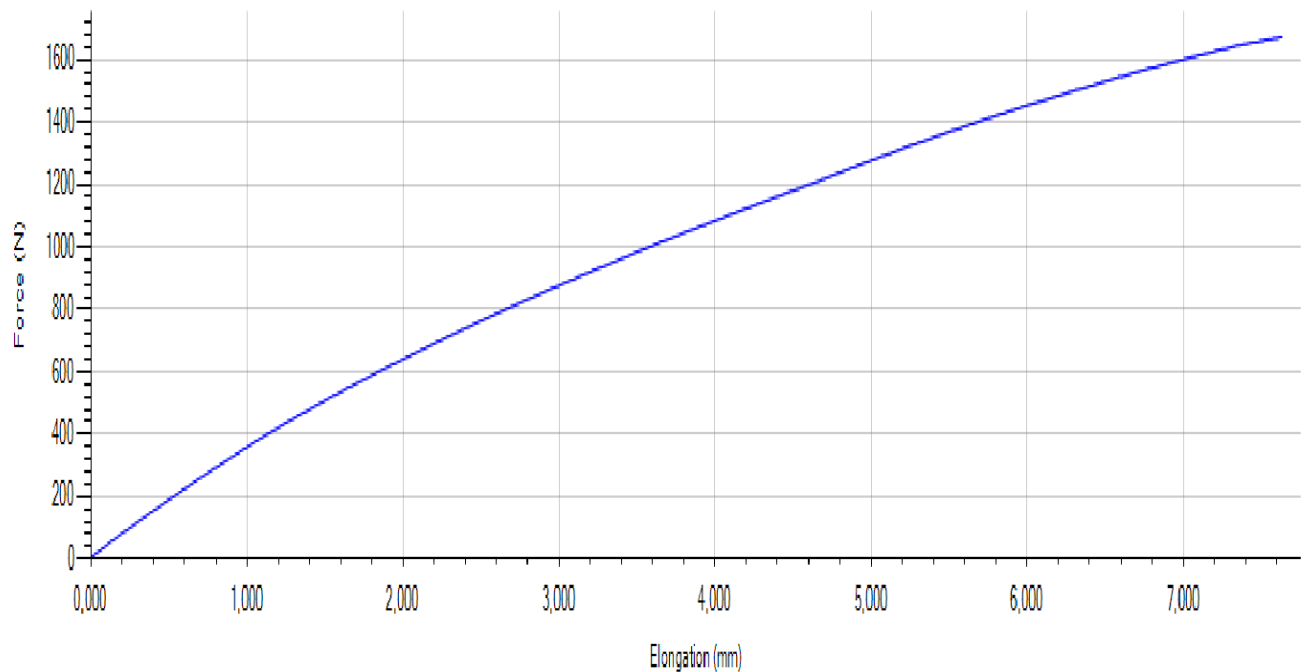

— Test 1



Unit 1 Lincoln Business Park Lincoln Close,
Rochdale, Lancashire, England OL11 1NR

Tel: (44) (0)1706 654039 Fax: (44) (0)1706 646089
Email: info@testometric.co.uk website: www.testometric.co.uk

Lampiran 9 Hasil uji tarik spesimen Raw Material

Testometric
materials testing machines

winTest™
Analysis

POLYPROPYLENE
Raw material

Ref 1 :
Ref 2 :
Ref 3 :

Test Name : ASTM D638 komposit
Test Type : Tensile
Test Date : 30/04/2019 11:02
Test Speed : 10,000 mm/min
Pretension : 5,000 N
Sample Length : 120,000 mm

Test No	Elong. @ Peak (mm)	Force @ peak (N)
T		

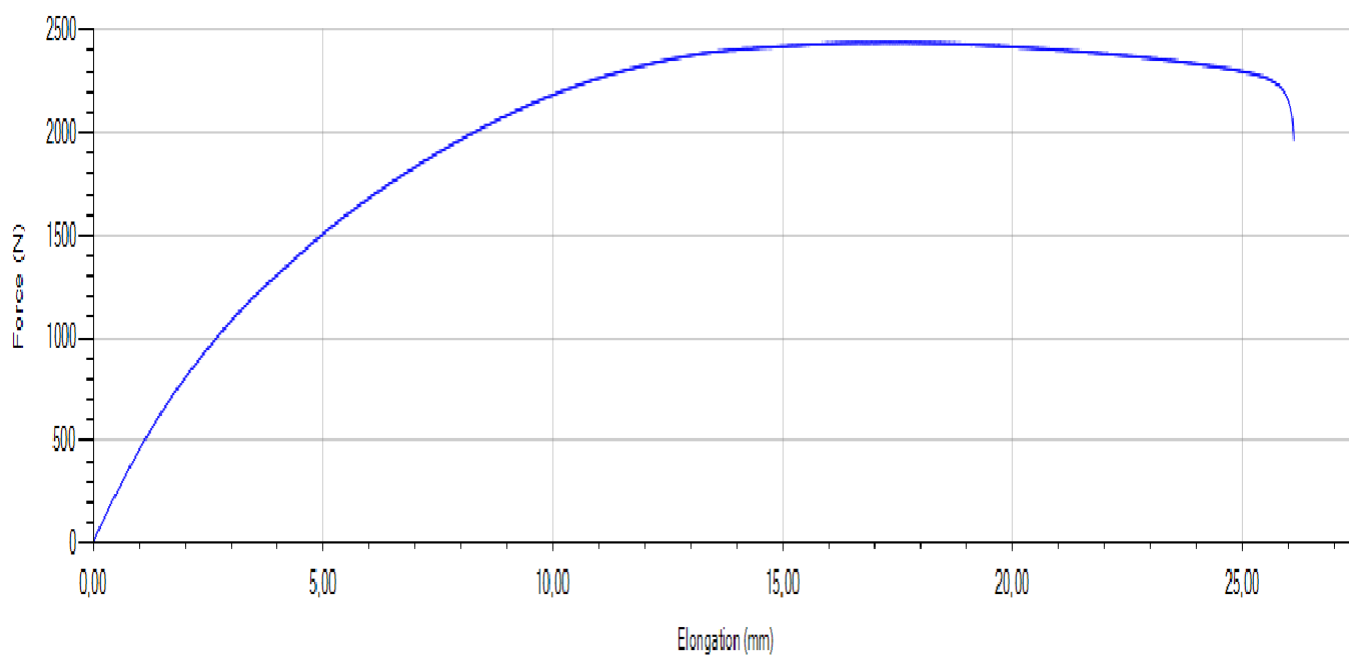

— Test 1



Unit 1 Lincoln Business Park Lincoln Close,
Rochdale, Lancashire, England OL11 1NR

Tel: (44) (0)1706 654039 Fax: (44) (0)1706 646089
Email: info@testometric.co.uk website: www.testometric.co.uk

Lampiran 10 Hasil uji tarik spesimen Perekat

Testometric
materials testing machines

winTest™
Analysis

POLYPROPYLENE

Perekat

Ref 1 :

Test Name : ASTM D638 komposit

Ref 2 :

Test Type : Tensile

Ref 3 :

Test Date : 30/04/2019 11:12

Test Speed : 10,000 mm/min

Pretension : 5,000 N

Sample Length : 120,000 mm

Test No	Elong. @ Peak (mm)	Force @ peak (N)
1	1,013	391,300

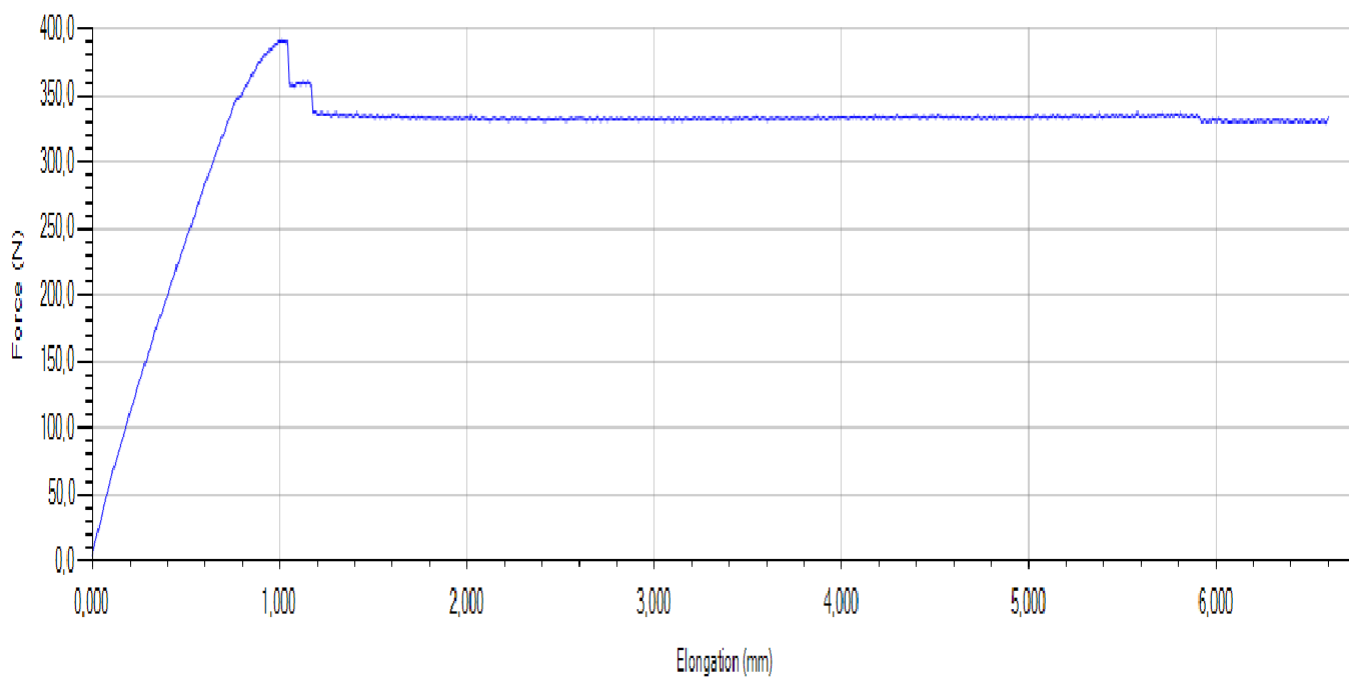

— Test 1



Unit 1 Lincoln Business Park Lincoln Close,
Rochdale, Lancashire, England OL11 1NR

Tel: (44) (0)1706 654039 Fax: (44) (0)1706 646089
Email: info@testometric.co.uk website: www.testometric.co.uk

Lampiran 11 Hasil Uji Kekerasan spesimen variasi kecepatan putar 588 RPM

**POLITEKNIK ATMI SURAKARTA**

Kampus I : Jl. Mojo No. 1, Karangasem, Laweyan, Surakarta 57145. Phone : +62 271 714466 • Fax : +62 271 714390

Kampus II : Jl. Adi Sucipto Km 9.5, Blulukan, Colomadu, Karanganyar 57174. Phone: +62 271 7686220

E-mail: politeknik@atmi.ac.id • Website: [http:// www.atmi.ac.id](http://www.atmi.ac.id)

Jawa Tengah, Indonesia



Hardness Test Report

Customer : Geriko Manabel Muhammad

Material : Polypropylene

Note : n = 588 RPM

Standart : Shore D

Result

	Point 1	Point 2	Point 3
Spesimen 1	47,5	46	51

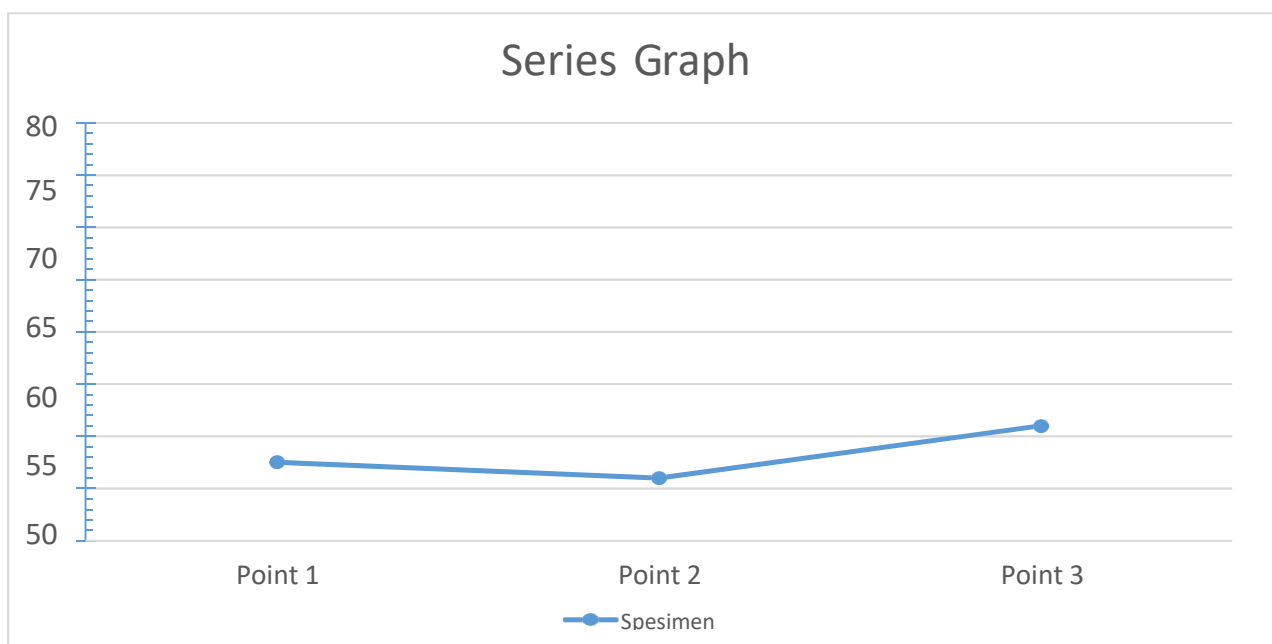

Statistics:

Series	Shore D
x	48,17
s	3,25
v [%]	6,75

Lampiran 12 Hasil Uji Kekerasan spesimen variasi kecepatan putar 977 RPM

**POLITEKNIK ATMI SURAKARTA**

Kampus I : Jl. Mojo No. 1, Karangasem, Laweyan, Surakarta 57145. Phone : +62 271 714466 • Fax : +62 271 714390

Kampus II : Jl. Adi Sucipto Km 9.5, Blulukan, Colomadu, Karanganyar 57174. Phone: +62 271 7686220

E-mail: politeknik@atmi.ac.id • Website: [http:// www.atmi.ac.id](http://www.atmi.ac.id)

Jawa Tengah, Indonesia



Hardness Test Report

Customer : Geriko Manabel Muhammad

Material : Polypropylene

Note : n = 977 RPM

Standart : Shore D

Result

	Point 1	Point 2	Point 3
Spesimen 1	60,5	55	59,5

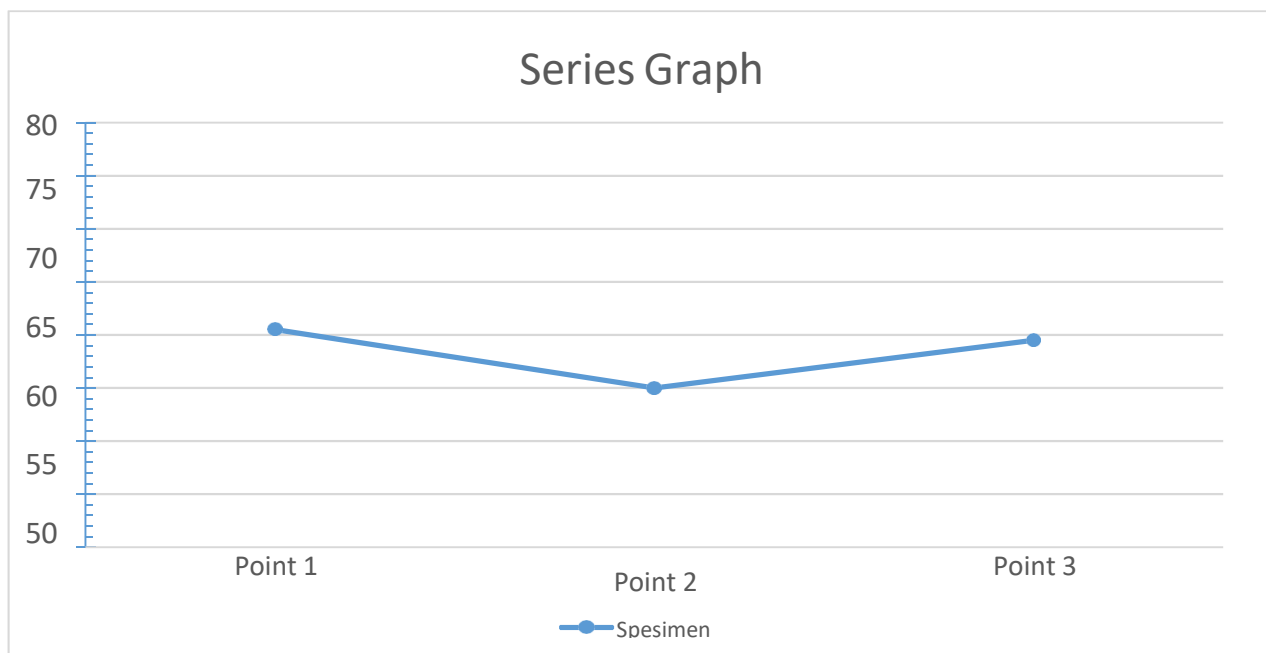

Statistics:

Series	Shore D
x	58,33
s	5
v [%]	8,57

Lampiran 13 Hasil Uji Kekerasan spesimen variasi kecepatan putar 1562 RPM

**POLITEKNIK ATMI SURAKARTA**

Kampus I : Jl. Mojo No. 1, Karangasem, Laweyan, Surakarta 57145. Phone : +62 271 714466 • Fax : +62 271 714390

Kampus II : Jl. Adi Sucipto Km 9.5, Blulukan, Colomadu, Karanganyar 57174. Phone: +62 271 7686220

E-mail: politeknik@atmi.ac.id • Website: [http:// www.atmi.ac.id](http://www.atmi.ac.id)

Jawa Tengah, Indonesia



Hardness Test Report

Customer : Geriko Manabel Muhammad

Material : Polypropylene

Note : n = 1562 RPM

Standart : Shore D

Result

	Point 1	Point 2	Point 3
Spesimen 1	54,5	48	55

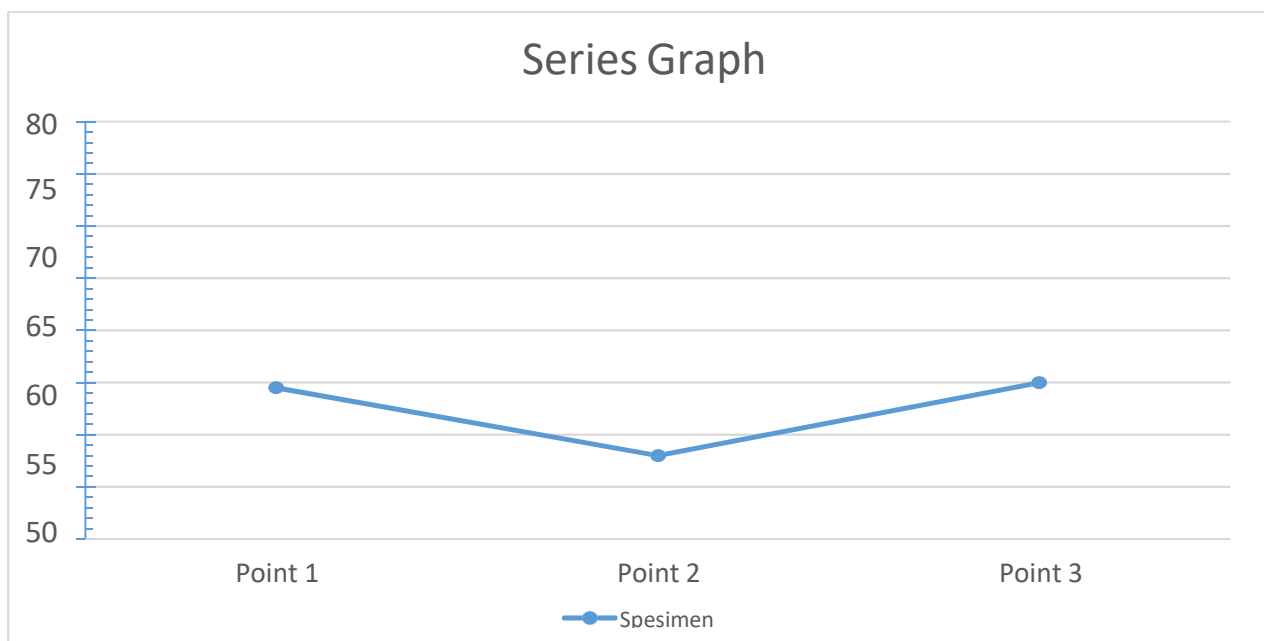

Statistics:

Series	Shore D
x	52,50
s	6,75
v [%]	12,86

Lampiran 14 Hasil Uji Kekerasan spesimen variasi kecepatan putar 2371 RPM

**POLITEKNIK ATMI SURAKARTA**

Kampus I : Jl. Mojo No. 1, Karangasem, Laweyan, Surakarta 57145. Phone : +62 271 714466 • Fax : +62 271 714390

Kampus II : Jl. Adi Sucipto Km 9.5, Blulukan, Colomadu, Karanganyar 57174. Phone: +62 271 7686220

E-mail: politeknik@atmi.ac.id • Website: [http:// www.atmi.ac.id](http://www.atmi.ac.id)

Jawa Tengah, Indonesia



Hardness Test Report

Customer : Geriko Manabel Muhammad

Material : Polypropylene

Note : n = 2371 RPM

Standart : Shore D

Result

	Point 1	Point 2	Point 3
Spesimen 1	54,5	52	53

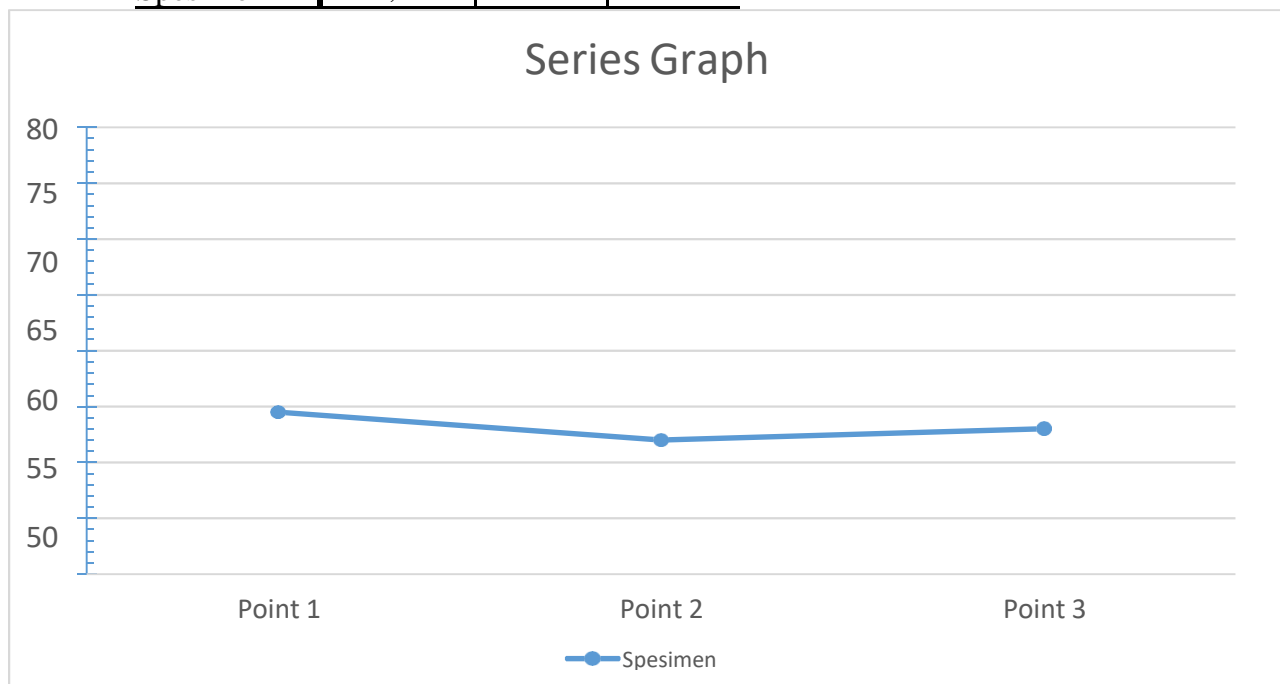

Statistics:

Series	Shore D
x	53,17
s	1,75
v [%]	3,29

Lampiran 15 Hasil Uji Kekerasan spesimen Raw Material

**POLITEKNIK ATMI SURAKARTA**

Kampus I : Jl. Mojo No. 1, Karangasem, Laweyan, Surakarta 57145. Phone : +62 271 714466 • Fax : +62 271 714390

Kampus II : Jl. Adi Sucipto Km 9.5, Blulukan, Colomadu, Karanganyar 57174. Phone: +62 271 7686220

E-mail: politeknik@atmi.ac.id • Website: [http:// www.atmi.ac.id](http://www.atmi.ac.id)

Jawa Tengah, Indonesia



Hardness Test Report

Customer : Geriko Manabel Muhammad
 Material : Polypropylene
 Note : n = Raw Material
 Standart : Shore D

Result

	Point 1	Point 2	Point 3
Spesimen 1	73	73,5	73

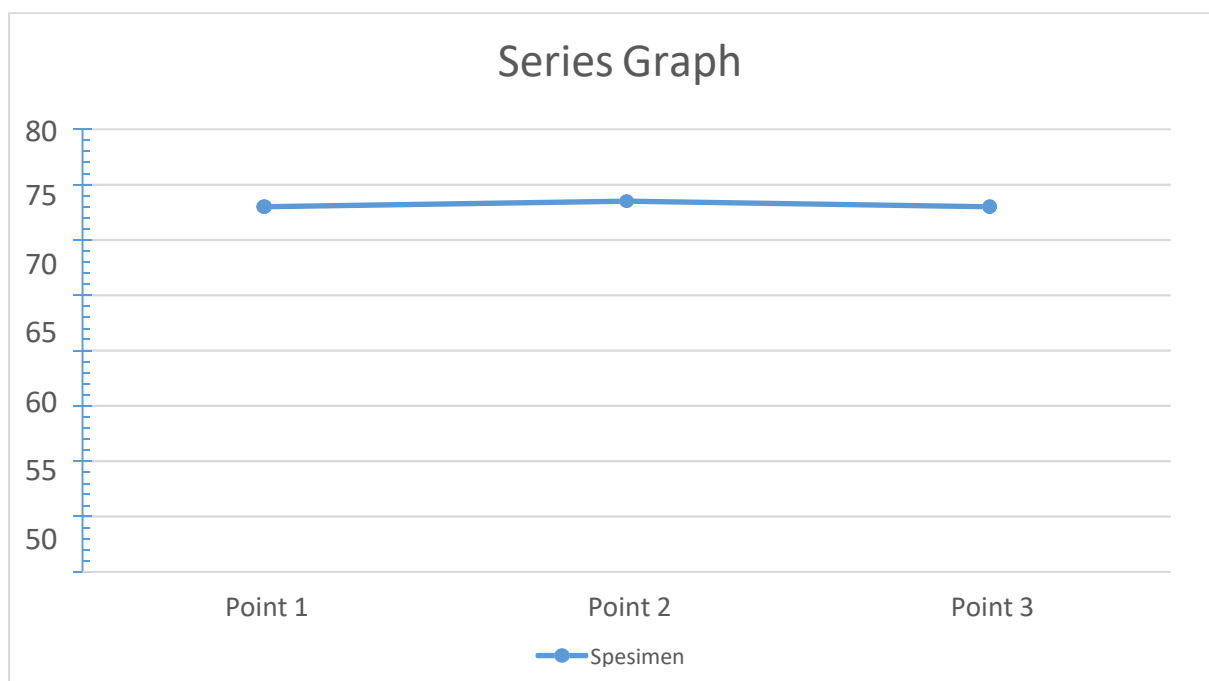

Statistics:

Series	Shore D
x	73,17
s	0,5
v [%]	0,68

Lampiran 16 Gambar teknik *pin tool* silinder ulir

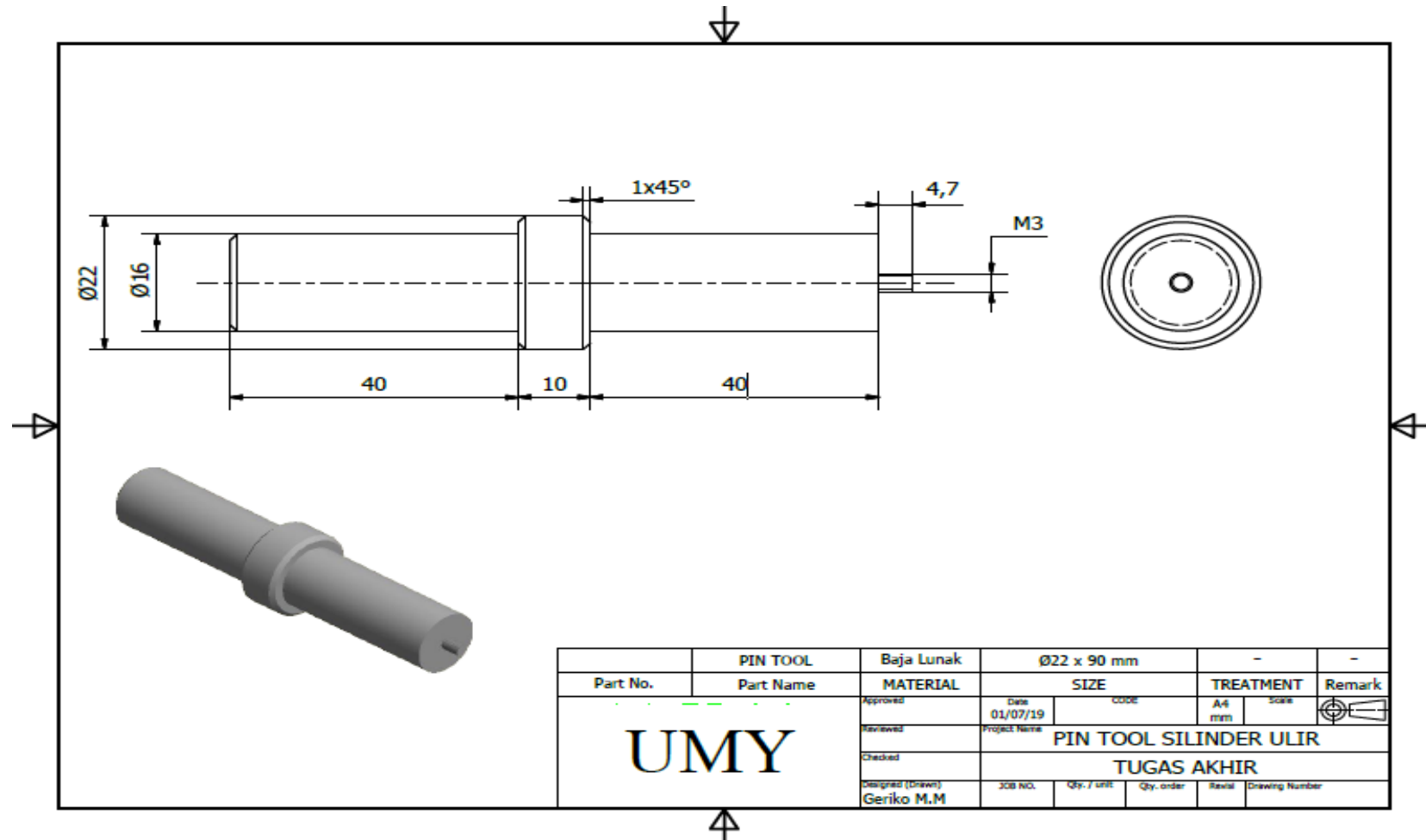

Lampiran 17 Gambar teknik spesimen dipotong sesuai standard ASTM D638

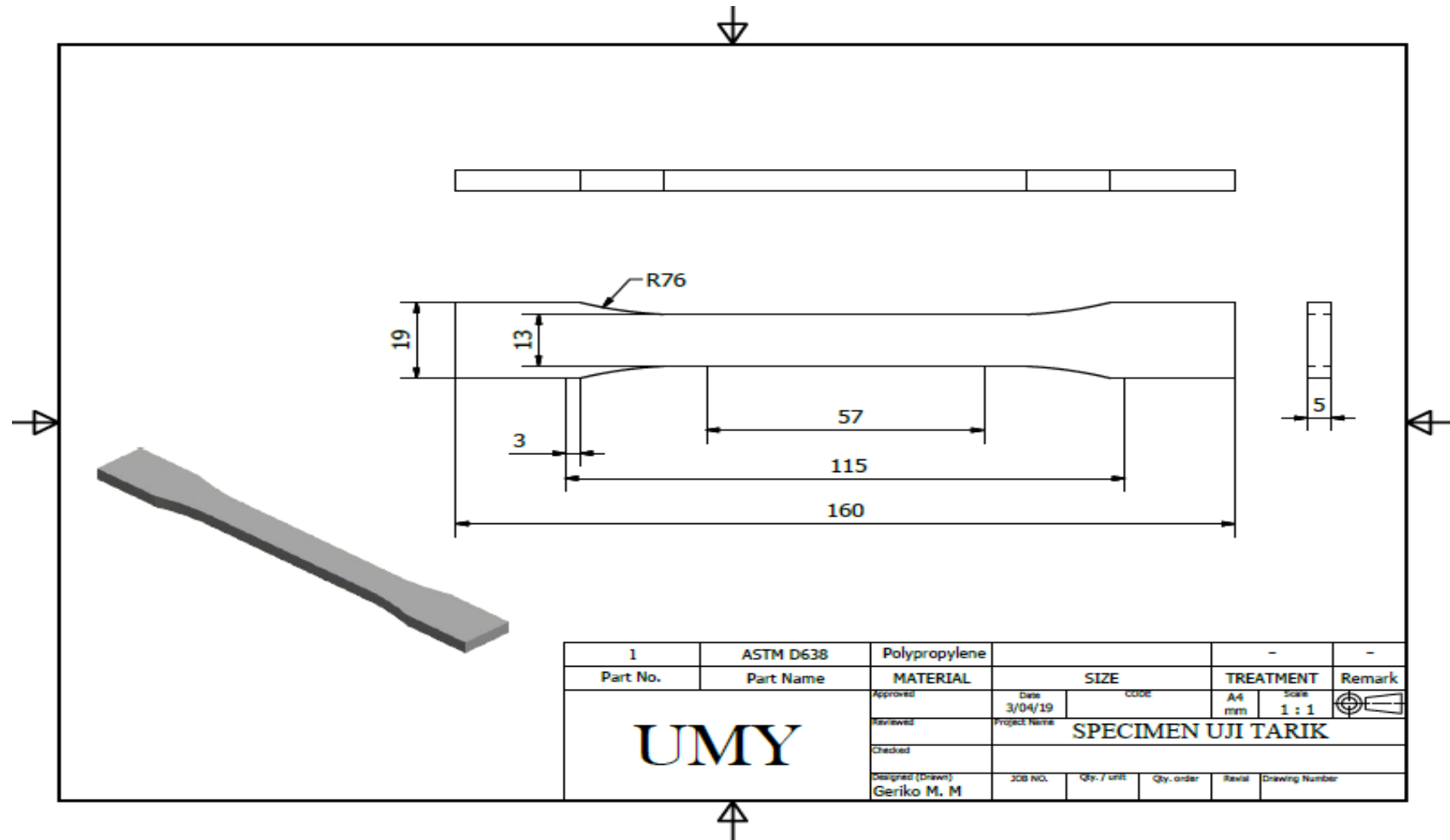

Lampiran 18 Hasil cek plagiasi naskah tugas akhir

PENGARUH KECEPATAN PUTAR PIN TOOL TERHADAP SIFAT MEKANIK PADA PENGELASAN FRICTION STIR WELDING POLYPROPYLENE (PP)

ORIGINALITY REPORT

16% <small>SIMILARITY INDEX</small>	14% <small>INTERNET SOURCES</small>	2% <small>PUBLICATIONS</small>	12% <small>STUDENT PAPERS</small>
---	---	--	---

PRIMARY SOURCES

1	jurnal.ft.uns.ac.id <small>Internet Source</small>	2%
2	docplayer.info <small>Internet Source</small>	2%
3	Submitted to Universitas Muria Kudus <small>Student Paper</small>	1%
4	www.scribd.com <small>Internet Source</small>	1%
5	lontar.ui.ac.id <small>Internet Source</small>	1%
6	retno-alatuji.blogspot.com <small>Internet Source</small>	1%
7	Santosh K. Sahu, Debasish Mishra, Raju P. Mahto, Vyas M. Sharma, Surjya K. Pal, Kamal Pal, Susanta Banerjee, Padmanav Dash. "Friction stir welding of polypropylene sheet", Engineering Science and Technology, an International Journal, 2018 <small>Publication</small>	1%
8	Submitted to Politeknik Negeri Bandung <small>Student Paper</small>	1%
9	id.123dok.com <small>Internet Source</small>	<1%
10	blog.ub.ac.id <small>Internet Source</small>	<1%
11	www.alatuji.com <small>Internet Source</small>	<1%
12	Submitted to Universitas Diponegoro <small>Student Paper</small>	<1%
13	link.springer.com <small>Internet Source</small>	<1%
14	wassakasatu.blogspot.com <small>Internet Source</small>	<1%
15	rekayasamesin.ub.ac.id <small>Internet Source</small>	<1%
16	eprints.unlam.ac.id <small>Internet Source</small>	<1%
17	etheses.uin-malang.ac.id <small>Internet Source</small>	<1%
18	www.mccrone.com <small>Internet Source</small>	<1%

19	Submitted to Universitas Muhammadiyah Yogyakarta Student Paper	<1%
20	riky-ramadhan.blogspot.com Internet Source	<1%
21	eprints.uns.ac.id Internet Source	<1%
22	Submitted to Texas Woman's University Student Paper	<1%
23	linknovate.com Internet Source	<1%
24	Santosh K. Sahu, Kamal Pal, Raju P. Mahto, Padmanav Dash. "Monitoring of friction stir welding for dissimilar Al 6063 alloy to polypropylene using sensor signals", The International Journal of Advanced Manufacturing Technology, 2019 Publication	<1%
25	id.scribd.com Internet Source	<1%
26	es.scribd.com Internet Source	<1%
27	Ali Moochani, Hamid Omidvar, Seyed Reza Ghaffarian, Seyed Mohammad Goushegir. "Friction stir welding of thermoplastics with a new heat-assisted tool design: mechanical properties and microstructure", Welding in the World, 2018 Publication	<1%
28	Submitted to Sriwijaya University Student Paper	<1%
29	kumpulandata-skripsi.blogspot.com Internet Source	<1%
30	M. Werner. "The effect of metallization on the ohmic contact resistivity to heavily B-doped polycrystalline diamond films", IEEE Transactions on Electron Devices, 7/1995 Publication	<1%
31	repository.unhas.ac.id Internet Source	<1%
32	yopyhenpristian.blogspot.com Internet Source	<1%
33	e-journal.uajy.ac.id Internet Source	<1%
34	eprints.umm.ac.id Internet Source	<1%
35	ummuazizah24.blogspot.com Internet Source	<1%
36	digi.lib.ttu.ee Internet Source	<1%

37	digilib.uns.ac.id Internet Source	<1 %
38	zombiedoc.com Internet Source	<1 %
39	www.revistabiomedica.org Internet Source	<1 %
40	R. Singh, V. Kumar, M.S.J. Hashmi. "Friction Stir Welding of Dissimilar Plastic-Based Material With Metal Powder Reinforcement", Elsevier BV, 2017 Publication	<1 %
41	core.ac.uk Internet Source	<1 %
42	yasniliyasbatam.blogspot.com Internet Source	<1 %
43	zadoco.site Internet Source	<1 %
44	text-id.123dok.com Internet Source	<1 %
45	eprints.ums.ac.id Internet Source	<1 %
46	eprints.umpo.ac.id Internet Source	<1 %
47	www.slideshare.net Internet Source	<1 %
48	Submitted to iGroup Student Paper	<1 %
49	retii.sttnas.ac.id Internet Source	<1 %
50	mafiadoc.com Internet Source	<1 %
51	repository.unpas.ac.id Internet Source	<1 %
52	smk-k3.blogspot.com Internet Source	<1 %
53	blogsuhu.blogspot.com Internet Source	<1 %
54	bayubimantara.wordpress.com Internet Source	<1 %
55	repository.up.ac.za Internet Source	<1 %
56	Shing-Chung Wong. "Mechanical properties and strain fatigue lives of insulation polymers", Journal of Materials Science, 01/2009 Publication	<1 %
57	sehat-jr.blogspot.com Internet Source	<1 %

58	Submitted to Henderson County High School Student Paper	<1%
59	Submitted to Sultan Agung Islamic University Student Paper	<1%
60	Submitted to Universitas Sebelas Maret Student Paper	<1%
61	Submitted to Universitas Brawijaya Student Paper	<1%

Exclude quotes On

Exclude matches Off

Exclude bibliography On

Program Studi Teknik Mesin

Lembar Persetujuan Naskah Publikasi dan Abstrak Tugas Akhir (TA)

Judul TA: Pengaruh Kecepatan Putar *Pin Tool* Terhadap Sifat Mekanik Pada Pengelasan *Friction Stir Welding Polypropylene (PP)*

Judul Naskah Publikasi: Pengaruh Kecepatan Putar *Pin Tool* Terhadap Sifat Mekanik Pada Pengelasan *Friction Stir Welding Polypropylene (PP)*

Nama Mahasiswa: Geriko Manabel Muhammad

NIM: 20150130096

Pembimbing 1: Ir. Aris Widyo Nugroho, M.T., Ph.D.

Pembimbing 2: Muh. Budi Nur Rahman, S.T., M.Eng.

Hal yang dimintakan pesetujuan *:

- | | | | |
|--|---|--------------------------------|--------------------------------|
| <input type="checkbox"/> Abstrak berbahasa Indonesia | <input type="checkbox"/> Naskah Publikasi | <input type="checkbox"/> | <input type="checkbox"/> |
| <input type="checkbox"/> Abstrak berbahasa Inggris | <input type="checkbox"/> | <input type="checkbox"/> | <input type="checkbox"/> |

*beri tanda ✓ di kotak yang sesuai

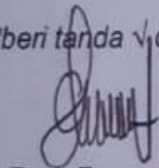

Tanda Tangan

Geriko Manabel Muhammad

Tanggal 27 Juli 2019

Persetujuan Dosen Pembimbing dan Program Studi

Disetujui

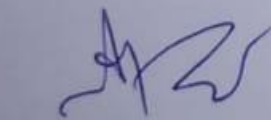

Tanda Tangan

Ir. Aris Widyo Nugroho, M.T., Ph.D.

Tanggal 27 Juli 2019

Tanda Tangan

Berli Paripurna Kamei, S. T., M.Eng. Sc., Ph.D.

Tanggal 22 Juli 2019

