

Correlation between Void Fraction -KEM.846.289

by Sukamta Sukamta

Submission date: 12-May-2020 04:32PM (UTC+0700)

Submission ID: 1322435081

File name: Artikel-Correlation_between_Void_Fraction_-KEM.846.289.pdf (893.57K)

Word count: 3480

Character count: 17507

Correlation between Void Fraction and Two-Phase Flow Pattern Air-Water with Low Viscosity in Mini Channel with Slope 30 Degrees

Sukamta^{1,a} and Sudarja^{1,b}

¹Mechanical Engineering Department, Faculty of Engineering, Universitas Muhammadiyah Yogyakarta, Jl. Lingkar Barat, Tamantirto, Kasihan, Bantul, Yogyakarta 55183, Indonesia

^asukamta@umy.ac.id, ^bsudarja@umy.ac.id

Keywords: Two-phase, Void Fraction, Flow Pattern, Viscosity, Image Processing

Abstract. Two-phase flow has been used in so many industrial processes, such as boilers, reactors, heat exchangers, geothermal and others. Some parameters which need to be studied include flow patterns, void fractions, and pressure changes. Research on void fractions aims to determine the composition of the gas and liquid phases that will affect the nature and value of the flow property. The purpose of this study is to find out the characteristics of the void fraction of various patterns that occurs and to determine the characteristics of the velocity, length, and frequency of bubbly and plug. Data acquisition was used to convert the data from analog to digital so that it can be recorded, stored, processed, and analyzed. High-speed camera Nikon type J4 was used to record the flow. The condition of the study was adiabatic with variation of superficial gas velocity (J_G), superficial liquid velocity (J_L), and also working fluid. To determine the void fraction by using the digital image processing method. The results of the study found that the flow patterns which occurred in this study were bubbly, plug, annular, slug-annular and churn flows. It also showed that the void fraction value is determined by the superficial velocity of the liquid and air. The higher the superficial velocity of the air, the lower the void fraction value.

Introduction

Void fraction is one of the parameters used to know the characteristics of two-phase flow. By deciding the void fraction, we can determine the several characteristics of the flow, namely relative velocity, the prediction of changes in flow pattern transition, heat transfer, calculation of the pressure drop, etc. One of the essential factors of this research which determines the void fraction in the a mini pipe is to get further knowledge and validate previous experiments with different methods. This research aims to know the flow characteristics, namely the velocity and frequency of flow pattern, and to determine the prediction of flow pattern transition changes, heat transfer, as well as to calculate the pressure drop used in the next research. [1] Measured void fraction using the constant flow method with small bubblys and large gas bubblys calibration. Analysis of void fractions was carried out by knowing the value of the liquid film thickness which encircles and surrounds the bubbly. The relationship between film thickness and gas superficial velocity (J_G) on the a horizontal flow was in the pipe size of 1 mm, 2,4 mm, 4,9 mm and 9 mm. [1] They Sstated that the film thickness value of those pipes was getting more significant with the increase of gas superficial velocity (J_G). On the contrary, in the pipeline with a diameter of 9 mm, the value of the film thickness decreased more and more with the increase of gas superficial velocity (J_G). Also, the data obtained from the intermittent flow pattern could be well linked to the data obtained from an annular flow pattern. [2] Measured the void fraction with the measurement of electrical conductivity in a flow. Two pairs of electrodes were installed in the inlet and outlet of the parallel plate with a gap between 0.778 mm - 1.465 mm. The void fraction was measured by comparing the ratio between the electrical conductivity of gas-liquid two-phase flow gas-liquid and electrical conductivity of liquid one-phase liquid flow. The result of this data would be converted into the form of a void fraction. [3] Compared the void fraction data which was estimated from the photograph taken from the circular test section with the predictions from several correlations. Except for annular flow where all the correlations tested were exceeded the data, homogenous model produced the best suitability with experimental results. [4] Measured

the void fraction in the pipe with the diameter of 100 μm . When the liquid fluid flowed with the low flow rate, the picture recorded was dominated by the flow without air ($\epsilon=0$), and the gas core flowed with a smooth liquid film. Meanwhile, when the average flow average was high, there were three recorded flows, namely single flow ($\epsilon=0$), gas core flow with smooth liquid film ($\epsilon=1$), and gas core flow with thick liquid film ($0 < \epsilon < 1$). Agnieszka Ładosz, etc. The following is the void fraction graph produced from the research by Kawahara et al. (2002). [5] For the first time demonstrates demonstrated for the first time a model for pressure drop prediction in three-phase liquid-liquid-gas slug flow. The proposed equation was successfully applied to oleic acid-water-nitrogen and heptane-nitrogen-water flows in capillaries of two different materials and sizes, with good agreement between experimental and theoretical results. They found that microchannel material can affect pressure drop tremendously if the magnitude of surface roughness exceeds the thickness of liquid film present around the gas or liquid slugs or if wettability of the wall material starts to play a role, i.e. so called dry-flow occurs. The presented model is simple and can be easily extended or reduced for slug flow cases where more or less than three-phases are present, including liquid-liquid and gas-liquid flows.

[6] Measured the average time of void fraction in the circular channel with a diameter of $D = 50, 100, 250, \text{ and } 530 \mu\text{m}$ as well as in the square channel with diameter of $96 \mu\text{m}$ by using the image analysis. Homogenous flow model had good suitability with the data for $D = 530 \mu\text{m}$. The data for $D = 530 \mu\text{m}$ was a little bit different from the homogenous flow model but was well suitable with the correlation proposed previously by Ali et al. (1993). It was that a two-phase flow in a narrow square channel with $D_h \sim 1 \text{ mm}$: $\alpha = 0.8 \beta$ and $\beta = J_G/J_L$ is volumetric quality. The data [7] for a square channel of $96 \mu\text{m}$ and 50 as well as $100 \mu\text{m}$ showed a very different tendency from those correlations but showed a non-linear relationship between α and β . [8] Conducted a research about gas-liquid two-phase flow in a horizontal pipe with diameter of 3.5 and 9 mm by using four kinds of liquid, namely; tap water, poly-oxy-ethylene lauryl solution, nonionic-polymer-fluorinate solution FC4430, and pure hydro fluoro ether 7200 with the gas fluid was air at atmospheric conditions. They reported that fluid properties greatly influence the flow pattern transition, especially the change of bubbly flow to the slug flow; and liquid properties do not have much effect on frictional pressure drop, but have a significant impact on the interfacial fraction force and void fraction, especially on bubbly and slug flows for $j_L = 2 \text{ m/s}$. [9] Measured the average void fraction in a channel with the diameter of 1.6 mm by using image analysis with software MATLAB. The result of the void fraction measurement compared to the homogeneous model was $\alpha = J_G/(J_G+J_L)$, the equation [10], the equation [11] where $\beta = (0.03\alpha^{0.5}) / (1-0.97\alpha^{0.5})$. They reported that the slug and bubbly flow were above the correlation line toward the homogeneous model. The position of void fraction of the slug and bubbly flow which was above the homogeneous line indicated that the slip ratio was valued of more than 1. It was because the actual speed of air is much greater than the actual speed of water. [12] Meanwhile, the void fraction of the churn, slug-annular, and annular flows were below the correlation line of the research; where they used pipe of 0.15 mm diameter and studied only for the throat-annular, serpentine-like gas core flows with the void fraction closed to the correlation line. [13] Studied the void fraction in which one of its results reported that generally, the increase of J_G affects the void fraction except for the very low J_G . It was because in that J_G the flow pattern was bubbly and plug. From the graph of homogenous void fraction (β) vs. measured void fraction (ϵ or α), for the bubbly flow, all the ϵ values were higher than the β value. Whereas, for the plug flow, the value of ϵ scattered around the correlation line of Ali et al. ($\epsilon = 0.8 \beta$) up to slightly above the homogeneous line. This could be seen because in the bubbly and plug flows there was no slip or even if there was a slip, the slip ratio was close to 1. For churn, plug-annular, (S-A), and annular flow patterns, the value of ϵ was minimal, even below the Kawahara correlation line. It was due to a substantial slip ratio, meaning the gas velocity is much greater than the liquid velocity. CFD on the plug two-phase flow gas-liquid in the horizontal pipe was conducted [14]. The flow was simulated at the gas superficial velocity (J_G) = $0.12\text{-}1.88 \text{ m/s}$ and liquid superficial velocity (J_L) = $0.16\text{-}1.13 \text{ m/s}$ in the temperature of 25°C . The result show that the superficial gas velocity significantly influenced the time variation of the liquid which is held in a very fluctuating plug flow because the emerge of the small bubbles in the gas phase. [15] conducted a research about the two-phase flow pattern on short horizontal rectangular

microchannels. The result of this research was the flow patterns of bubble, annular, jet, stratified and churn regimes. The investigation of two-phase flow, holding fluid and the decreasing pressure in the thick oil-gas flow were also studied [16]. The result was the flow pattern of stratified, stratified wavy, bubbly flow, plug flow, roll-wave, and slug flow. The pressure drops and flow pattern visualization were investigated. In air-water two-phase flow with a sudden magnification of a rectangular section of a vertical channel. The water discharge was 0.04-0.28 dm³/s, and the air discharge was 6.06-0.39 dm³/s. The visualization showed that the changes of flow pattern did not depend on the water or air discharge but the changes of cross-sectional area [17]. A measurement method, which is a combination of the multiwave UVP method and WMT, has been applied to the measurement of bubbly two-phase flow in vertical pipe. Regarding the measurements of counter-current bubbly flow of air water in the vertical pipe, measured data showed that the effect of initial flow conditions, e.g. bubble size, on the pattern of cross-sectional void fraction distribution was confirmed; measured data of instantaneous profiles of void fraction and velocity can contribute to the assessment and development of numerical simulation of two-phase flow [18].

Research Method

The experimental set up used in this research are shown in Fig. 1. The measuring tools used in this research are among other: water flow meter, air flow meter, temperature indicator, thermocouple, pressure indicator, and pressure transducer. High-speed camera Nikon type J4, with a speed of 1200 fps and a resolution of 640 x 480 pixels, is used for video shooting of the flow. Data acquisition was used to convert data from analog to digital so that it can be recorded, stored, processed, and analyzed on a computer. The condition of the study was adiabatic. Experiments were carried out at the superficial gas velocity (J_G) intervals of 0.025 - 66.3 m/s, and superficial fluid velocity (J_L) at intervals of 0.033 - 4,935 m/s. This research was conducted in 4 stages (based on working fluid), namely: air-water + 0% glycerin, air-water + 10% glycerin, air-water + 20% glycerin, and air-water + 30% glycerin. This research was conducted to determine the void fraction by using a digital image processing method.

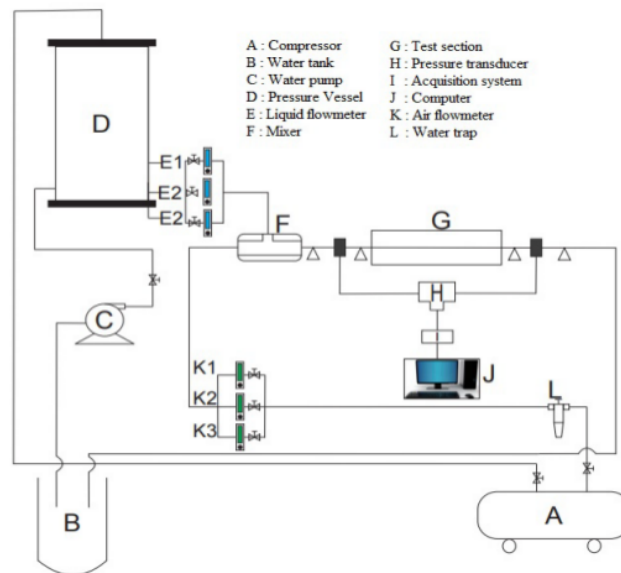

Fig. 1. Experiment set up

Result and Discussion

The bubbly flow pattern is shown by the appearance of an air bubble formed like a small sphere floating between the walls of the pipe (Fig.2). This flow pattern is formed when the superficial gas velocity (J_G) is low, and the liquid superficial velocity (J_L) is high.

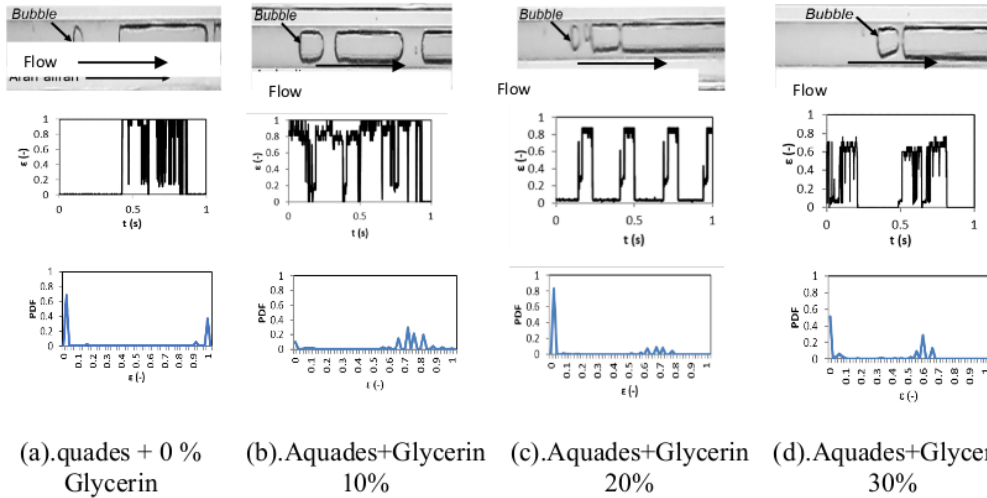

Fig. 2. Bubbly flow pattern with $J_G = 0.116$ m/s and $J_L = 0.89$ m/s

The plug flow pattern is often marked with the air bubbles which covers the whole pipe wall with various flow pattern lengths (Fig. 3). It shows that the plug diameter is the same as the diameter of the mini pipe. Based on the phase, the plug flow pattern can be differentiated into two, namely the air plug and water plug.

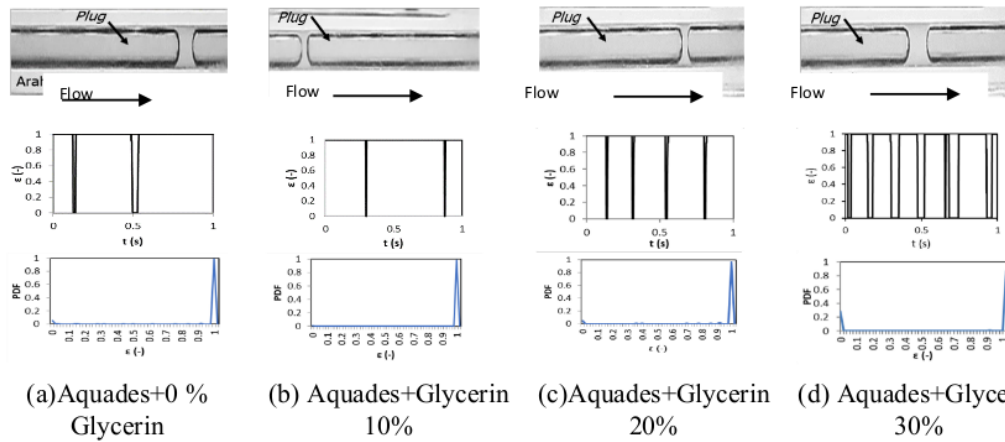

Fig. 3. Plug Flow Pattern with $J_G = 0.116$ m/s and $J_L = 0.033$ m/s

The plug is the flow pattern which based on the form is categorized as the large bubbly flow (elongated bubbly).

Bubbly and plug velocity can be found by determining the interlude between the movement of bubbly and plug from one reference point to another. The value of cross-correlation bubbly can be seen in Fig.4. It can be observed a fluctuation which contains the value that shows the interlude. The highest peak represents the interlude resulted from cross-correlation. Furthermore, the value of the bubble and plug velocity is calculated from the distance of both used references divided by the

specific interlude. If the viscosity increases, then the bubbly and plug velocity will decrease. This phenomenon is caused by the difficulty of air to enter the glycerin mixed pipe flow, and the aquades has the increasing viscosity.

The velocity of bubbly and plug flow pattern was then plotted and provided in Fig.5. The graph is made by connecting the bubbly and plug velocity with volumetric flux total, then the velocity of bubble and plug will increase. Fig.5 presents the graph of plug and bubbly length that are decided by using the method of manual calculation. The manual calculation is done to the bubbly and plug that flow in 1 second, and then the average is calculated to determine the length of bubbly and plug. After the result is known ($\Delta t = t_2 - t_1$) and the velocity from cross-correlation is obtained (v), it can be obtained the value of bubbly and plug length by calculating ($L = \Delta t.v$). Based on the received result, there is the only little bubbly length that has the size less than the diameter of the pipe. This result is caused by the bubbly flow is also found in the plug flow.

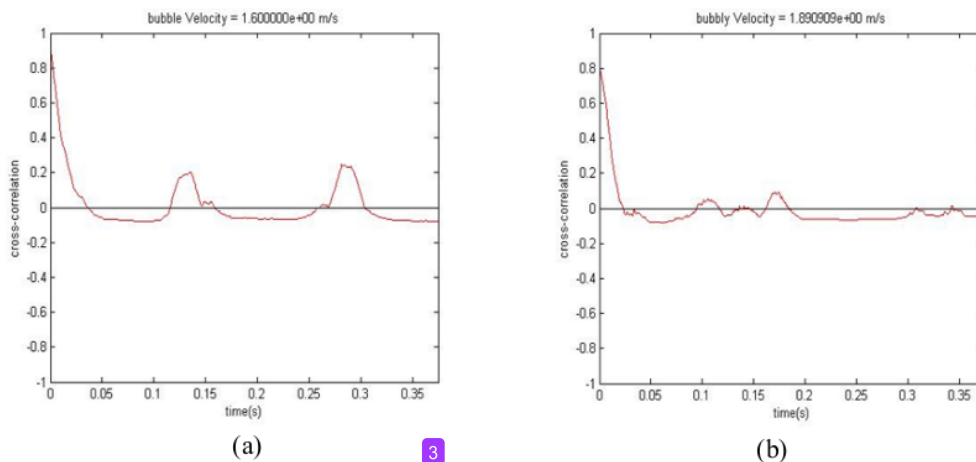

Fig. 4. Cross-Correlation bubbly in (a) $J_G = 0.025$ m/s $J_L = 0.89$ m/s and (b) $J_G = 0.116$ m/s $J_L = 0.89$ m/s

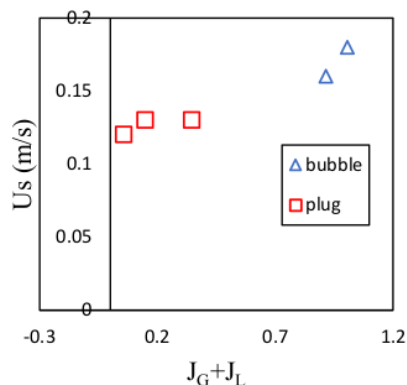

Fig. 5. The Velocity of Bubble and Plug

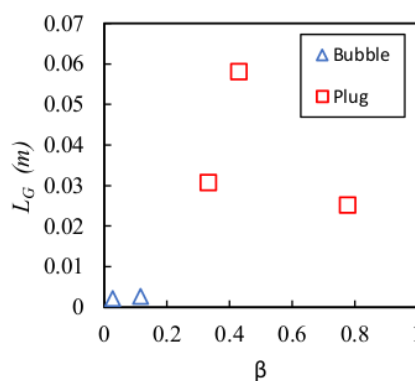

Fig. 6. The Length of Bubbly and Plug

The length will affect the average of bubbly and plug (Fig. 6). The void fraction of the bubbly flow pattern will increase significantly over a period caused by the emergence of plugs. In the flow pattern, the void fraction plug will reach one at a certain time range. It is because the plug meets the test section of the channel. The bubbly and plug flow patterns are greatly influenced by the viscosity of the fluid. It is because of the higher the viscosity of the fluid, the faster the velocity of the bubbly and plug flow patterns, and the lower the viscosity of the fluid, the faster the velocity of the bubbly and

plug flow patterns. The lengths of the bubbly and the plug patterns are influenced by the higher homogeneous value which makes the length of the pattern increases. The frequency of bubbly and plug is quite high, which increases the void fraction.

Conclusion

When superficial gas velocity (J_G) is increasing, then the obtained void fraction will increase. On the contrary, when superficial liquid velocity (J_L) is increasing then, the void fraction will decrease. The flow pattern of bubbly and plug is significantly affected by the total of volumetric flux. This phenomenon is caused by the higher J_T ($J_G + J_L$), the higher flow pattern velocity. The length of bubbly and plug flow pattern is affected by the value of (β) when the value of (β) is increasing then, the length of the flow pattern increase. Moreover, the length of both flow patterns is also affected by the homogeneity. The length of bubbly and plug are affected by the obtained J_G and J_L . At the frequency when bubbly and the plug occurred – high enough frequency, the value of the void fraction is increasing enough.

Acknowledgement

Ministry of Research, Technology and Higher Education of the Republic of Indonesia supported this research with the contract no: 007/HB-LIT/II/2018, February 15th, 2018 and Yudia Rahman measured data.

References

- [1] Fukano T. and Kariyasaki A., "Characteristics of Gas-Liquid Two-Phase Flow in a Capillary Tube," *Nucl. Eng. Des.*, vol. 141, pp. 59–68, (1993).
- [2] A. M.I., M. Sadatomi, and M. Kawaji, "Adiabatic Two-Phase Flow in Narrow Channels Between Two Flat Plates," *Can. J. Chem. Eng.*, vol. 71, no. 5, pp. 657–666, (1993).
- [3] K. A. Triplett, S. M. Ghiaasiaan, S. I. Abdel-Khalik, and D. I. Sadowski, "GasLiquid Two-Phase Flow in Microchannels Part II: void fraction and pressure drop," *Int. J. Multiph. Flow*, vol. 28, pp. 395–410, (1999).
- [4] K. A. C. P.M., and K. M., "Investigation of Two-Phase Flow Pattern, Void Fraction and Pressure Drop in a Microchannel," *Int. J. Multiph. Flow*, vol. 28, pp. 1411–1435, (2002).
- [5] Agnieszka Ładosz, Eugen Rigger And Philipp Rudolf Von Rohr, "Pressure Drop of Three-Phase Liquid-Liquid-Gas Slug Flow in Round Microchannels", *Proceeding of Microfluidics and Nanofluidics*, <https://link.springer.com/article/10.1007/s10404-016-1712-7>. (29 February 2016)
- [6] P. M. Y. Chung and M. Kawaji, "The effect of Channel Diameter on Adiabatic Two-Phase Flow Characteristics in Microchannel," *Int. J. Multiphase Flow*, vol. 30, pp. 735–761, (2004).
- [7] Chung, P.M.Y., Kawaji, M., The Effect of Channel Diameter on Adiabatic Two-Phase Flow Characteristic in Microchannels, *International Journal of Multiphase Flow*, Vol. 30, pp. 735-761, (2004).
- [8] M. Sadatomi, A. Kawahara, M. Matsuo, and K. Ishimura, "Effects of Surface Tension on Two-Phase Gas-Liquid Flows in Horizontal Small Diameter Pipes," *Journal Power Energy Syst.*, vol. 4, no. 2, pp. 290–300, (2010).
- [9] Sudarja, Deendarlianto, Indarto, and H. Aqli, "Experimental Study on the Void Fraction of Air-Water Two-Phase Flow in a Horizontal Circular Mini-Channel," in *AIP Conference Proceeding*. (2015).

-
- [10] S. Saisorn and S. Wongwises, "Flow Pattern, Void Fraction and Pressure Drop of Two-Phase Air-Water Flow in a Horizontal Circular Micro-Channel," *Exp. Therm. Fluid Sci.*, vol. 32, no. 3, pp. 748–760. (2008).
- [11] M.I. Ali, M. Sadatomi, M. K. Adiabatic Two-Phase flow in narrow channels between two flat plates, 71, 657–666. (1993).
- [12] Serizawa, A., Feng, Z., & Kawara, Z. Two-phase flow in microchannels. *Experimental Thermal and Fluid Science*. (2002).
- [13] Mayor, T.S., Pinto, A.M.F.R., Campos, J.B.L.M., 2007, An Image Analysis Technique for The Study of Gas-Liquid Slug Flow along Vertical Pipes – Associated Uncertainty, *Flow Measurement and Instrumentation*, Vol 18, pp. 139-147.
- [14] Deendarlianto, M. Andrianto, A. Widyaparaga, O. Dinaryanto, Khasani, and Indarto, "CFD Studies on the Gas-Liquid plug two-phase flow in a horizontal pipe", *Journal of Petroleum Science and Engineering*, 2016.
- [15] E. A. Chinnov, F. V. Ron'shin, and O. A. Kabov, "Two-Phase Flow Patterns In Short Horizontal Rectangular Microchannels", *International Journal Of Multiphase Flow*, 2015.
- [16] H. A. Khaledi, I. E. Smith, T. E. Unander, and J. Nossen, "Investigation Of Two-Phase Flow Pattern, Liquid Holdup and Pressure Drop In Viscous Oil-Gas Flow", *International Journal Of Multiphase Flow*, 37-51, 2014.
- [17] R. Sihombing: "Pressure Drop of Liquid and Gas Flow at Sudden enlargement cross-section of Rectangle Vertical Channels." *Electronic ROTOR Journal*, Vol. 1. (2013).
- [18] Tat Thang Nguyen, Hiroshige Kikura, Hideki Murakawa, Nobuyoshi Tsuzuki, Measurement of bubbly two-phase flow in vertical pipe using multiwave ultrasonic pulsed Doppler method and wire mesh tomography, *Energy Procedia*, Vol. 71 (2015), p. 337-351.

Correlation between Void Fraction -KEM.846.289

ORIGINALITY REPORT

14%

SIMILARITY INDEX

11%

INTERNET SOURCES

11%

PUBLICATIONS

2%

STUDENT PAPERS

PRIMARY SOURCES

1

link.springer.com

Internet Source

4%

2

garuda.ristekdikti.go.id

Internet Source

3%

3

aip.scitation.org

Internet Source

3%

4

Nguyen, Tat Thang, Hiroshige Kikura, Hideki Murakawa, and Nobuyoshi Tsuzuki.

"Measurement of Bubbly Two-phase Flow in Vertical Pipe Using Multiwave Ultrasonic Pulsed Doppler Method and Wire Mesh Tomography", Energy Procedia, 2015.

Publication

3%

Exclude quotes On

Exclude bibliography On

Exclude matches < 2%